

CHECK BEING PERFORMED: Custom

ZONES: 160  
 A/C NUMBER:  
 REV. DATE: 06/06/06  
 FREQUENCY: S2C

W/C NUMBER: 210I5308  
 DATE:  
 W/O:  
 JAC CODE:

## PANELS

822	1611	1621	2215
1001	1612	1652	

## REFERENCES

1 CP53-251(252)-02I

MECH INSP

{CPCP} FLOOR BEAMS AND DOOR SILLS, BS 1540 - BS 1720

ACCESS NOTE: THESE INSPECTIONS ARE MOSTLY PERFORMED FROM WITHIN THE LOWER BILGE AREA ACCESSED THROUGH CARGO DOOR 822. THE EXCEPTION IS STEP 3.A.(2), WHICH IS PERFORMED FROM WITHIN THE CABIN.

1. PERFORM THE FOLLOWING INSPECTIONS UNDER THE G4A GALLEY.

|XXXX \_\_\_\_\_ A. BS 1602 - BS 1640, RIGHT SIDE.

(1) PERFORM A DETAILED INTERNAL INSPECTION OF THE FLOOR BEAMS AND SEAT TRACKS, BODY SKIN, STRINGERS AND FRAMES IMMEDIATELY BELOW AND ADJACENT TO THE GALLEY ABOVE.

2. PERFORM THE FOLLOWING LOWER DOOR SILL INSPECTIONS.

|XXXX \_\_\_\_\_ A. PERFORM A DETAILED INTERNAL INSPECTION OF THE L4 AFT LEFT SERVICE DOOR CUTOUT LOWER SILL (BS 1640 - BS 1675, LEFT SIDE).

B. PERFORM A DETAILED INTERNAL INSPECTION OF THE R4 AFT RIGHT SERVICE DOOR CUTOUT LOWER SILL (BS 1640 - BS 1675, RIGHT SIDE).

3. PERFORM THE FOLLOWING INSPECTIONS UNDER THE G4B GALLEY.

NOTE: CABIN EQUIPMENT REMOVAL NOT REQUIRED FOR C-2 CHECK. FLOORBOARDS ARE REMOVED BETWEEN BS 1637 AND BS 1682 FOR ACCESS ON THE C2 AND C4 CHECKS.

A. BS 1640 - BS 1720.

|XXXX \_\_\_\_\_ (1) {CP53-251(252)-02I} PERFORM A DETAILED INTERNAL INSPECTION OF THE FLOOR BEAMS, BODY SKIN, STRINGERS & FRAMES IMMEDIATELY BELOW AND ADJACENT TO THE GALLEY ABOVE. CLEAR ANY BLOCKED HOLES OR GAPS THAT MAY HINDER

A/C NUMBER:

CHECK BEING PERFORMED: Cust

W/C NUMBER: 210I5308 (continued)

MECH: INSP:

| DRAINAGE.

|XXXX (2) {CP53-251(252)-02I} PERFORM A DETAILED INSPECTION OF THE UPPER SURFACE OF THE FLOORBEAMS EXPOSED BY THE REMOVAL OF FLOORBOARDS BETWEEN BS 1637 AND BS 1682. CLEAR ANY BLOCKED HOLES THAT MAY HINDER DRAINAGE.

| FOR CRACKS, PERMANENT DEFORMATION, OR CORROSION TO PRIMARY STRUCTURE (REF. SRM CHAPTER 51); INITIATE A SERVICE DIFFICULTY REPORT (SDR) (REF. GMM, CHAPTERS 4, 12, AND 16) AND RECORD THE ASSOCIATED NON-ROUTINE NUMBERS BELOW.

Four horizontal lines for handwritten notes.

|XXXX (3) PERFORM A DETAILED INTERNAL INSPECTION OF THE AREAS AFT OF THE BULK CARGO COMPARTMENT INCLUDING BODY SKIN, STRINGERS AND FRAMES BETWEEN BS 1640 AND BS 1720, FROM STRINGER S-26L TO STRINGER S-26R, INCLUDING THE LOWER PORTION OF THE BODY STATION 1720 BULKHEAD (BELOW FLOOR LEVEL).

|XXXX (4) PERFORM A DETAILED INTERNAL INSPECTION OF THE BODY STATION 1720 BULKHEAD HORIZONTAL BEAMS (WL 180 & 200) AND AREAS OF ATTACHMENT TO THE VERTICAL BEAMS AND VISIBLE AREAS OF CABIN FLOOR/BULKHEAD LUGS AT BL 9.2, BL 27.7 AND BL 45.7.

\*\*\*\*\*END OF WORKCARD\*\*\*\*\*

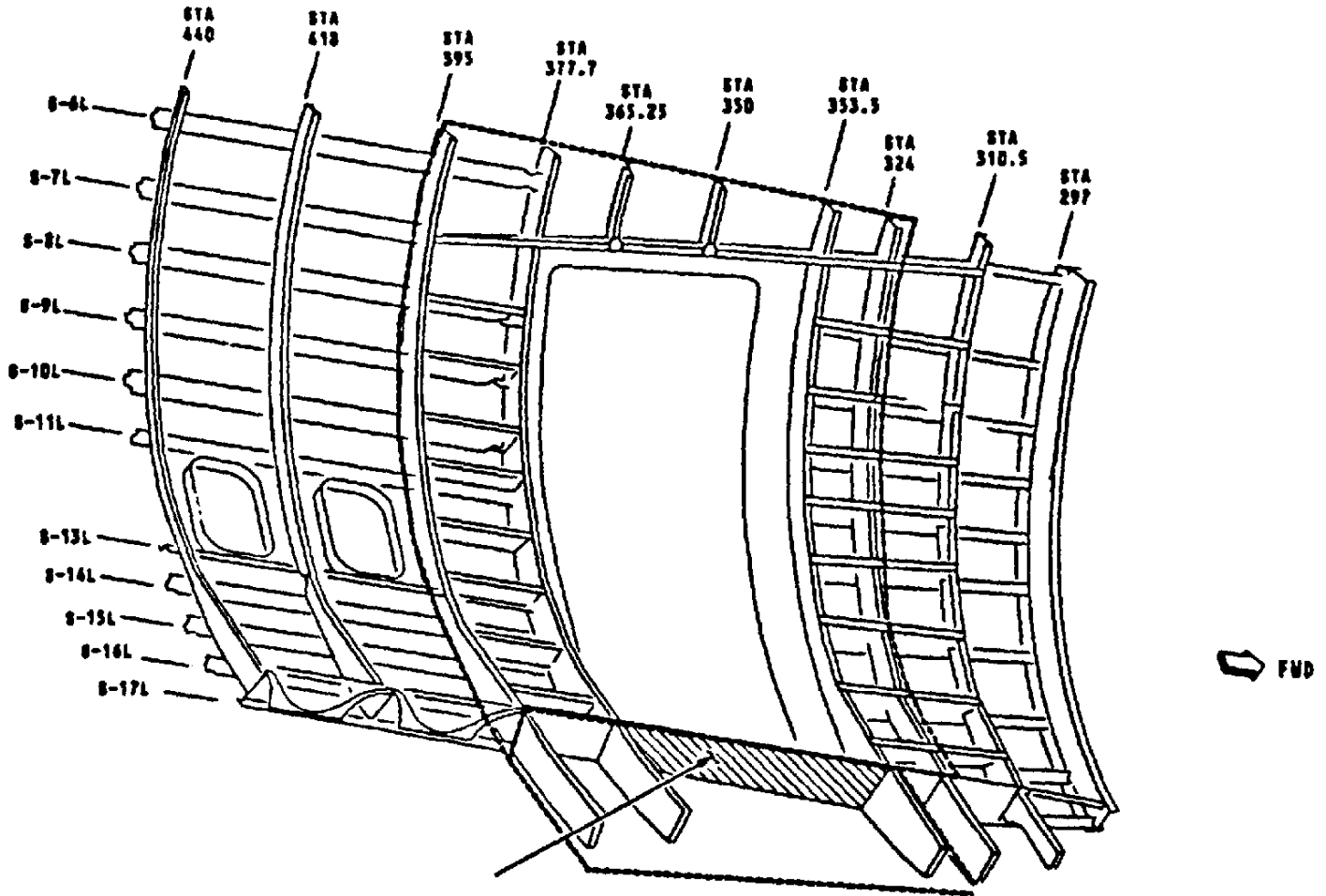

PASSENGER DOOR CUTOUT STRUCTURE (TYPICAL 6 PLACES) LH FORWARD SHOWN