

ATA AIRLINES, INC.

{CPCP} LOWER LOBE INTERIOR, BS 1480 - BS 1640, S17 - S26 (L/R)

PAGE 1 / 1

CHECK BEING PERFORMED: Custom

ZONES: 161 162
A/C NUMBER:
REV. DATE: 06/06/06
FREQUENCY: PCI

W/C NUMBER: 212I5376
DATE:
W/O:
JAC CODE:

PANELS

822 1001 1612 8231
823 1611 1621

REFERENCES

1 CP53-161(162)-01I

MECH INSP

{CPCP} LOWER LOBE INTERIOR, BS 1480 - BS 1640, S17-26 (L/R)

1. PERFORM THE FOLLOWING VISUAL INSPECTION

A. {CP53-161(162)-01I} VISUALLY INSPECT THE LOWER FUSELAGE LOBE INCLUDING SKIN PANELS, SKIN SPLICES AND JOINTS, FRAMES AND STRINGERS, SHEAR TIES, SKIN CUTOUTS, WITH PARTICULAR ATTENTION TO LONGITUDINAL LAP SPLICES, CIRCUMFERENTIAL SKIN BUTT JOINTS, DOOR CUTOUTS AND LOWER SILLS, AREAS UNDER LAVS AND GALLEYS INCLUDING MAIN DECK FLOOR STRUCTURE, SKIN DOUBLERS AT LAVATORY SERVICE PANEL CUTOUTS, AND OUTFLOW VALVE CUTOUT STRUCTURE. CLEAR ANY BLOCKED HOLES OR GAPS THAT MAY HINDER DRAINAGE.

FOR CRACKS, PERMANENT DEFORMATION, OR CORROSION TO PRIMARY STRUCTURE (REF. SRM CHAPTER 51); INITIATE A SERVICE DIFFICULTY REPORT (SDR) (REF. GMM, CHAPTERS 4, 12, AND 16) AND RECORD THE ASSOCIATED NON-ROUTINE NUMBERS BELOW.

Four horizontal lines for recording data.

*****END OF WORKCARD*****

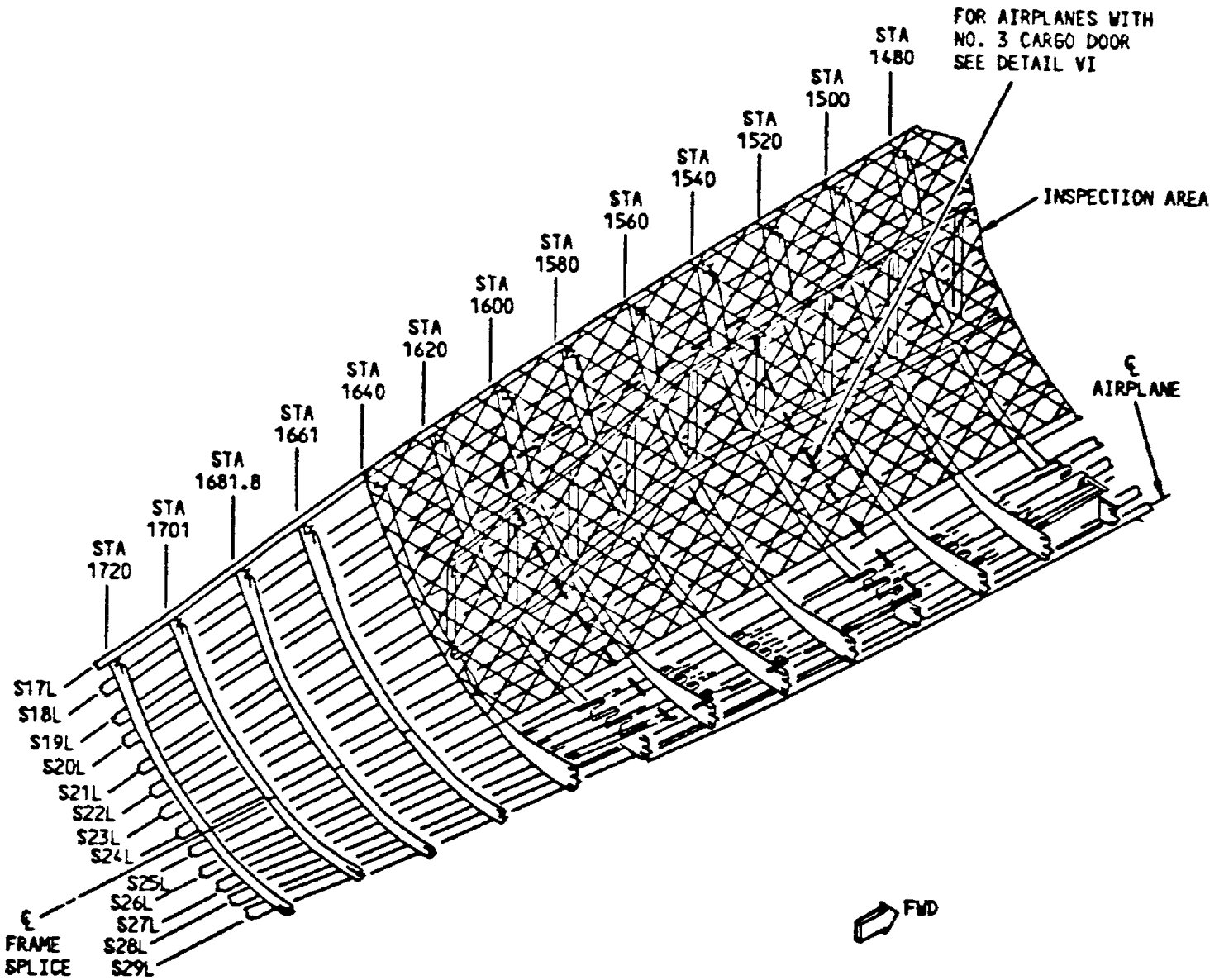

LEFT SIDE SHOWN
RIGHT SIDE OPPOSITE EXCEPT AS NOTED

SECTION 46 - INTERIOR STRUCTURE
BS 1480 TO BS 1720