

VACUUM RELIEF VALVES

A/C NUMBER:

CHECK BEING PERFORMED: Cust

W/C NUMBER: 214F2102 (continued)

MECH: INSP:

_____ XXXXX 8 Check the fabric splash guard curtain installed behind the
valve doors for condition and security
(Ref. E.O. 757-53SG-1878).

*****END OF WORKCARD*****

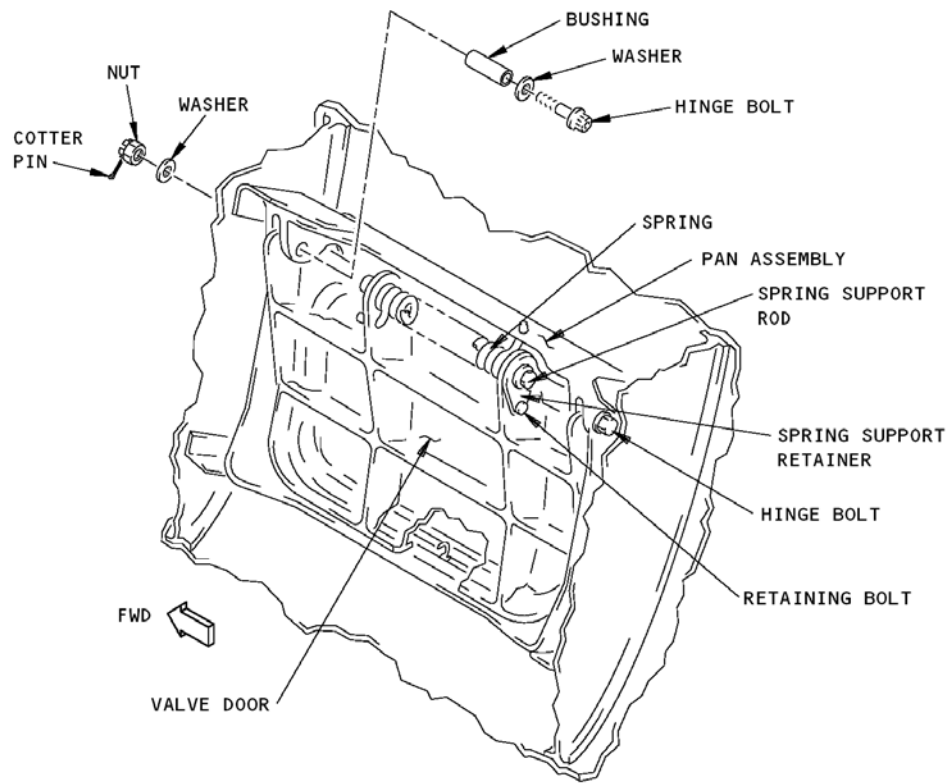
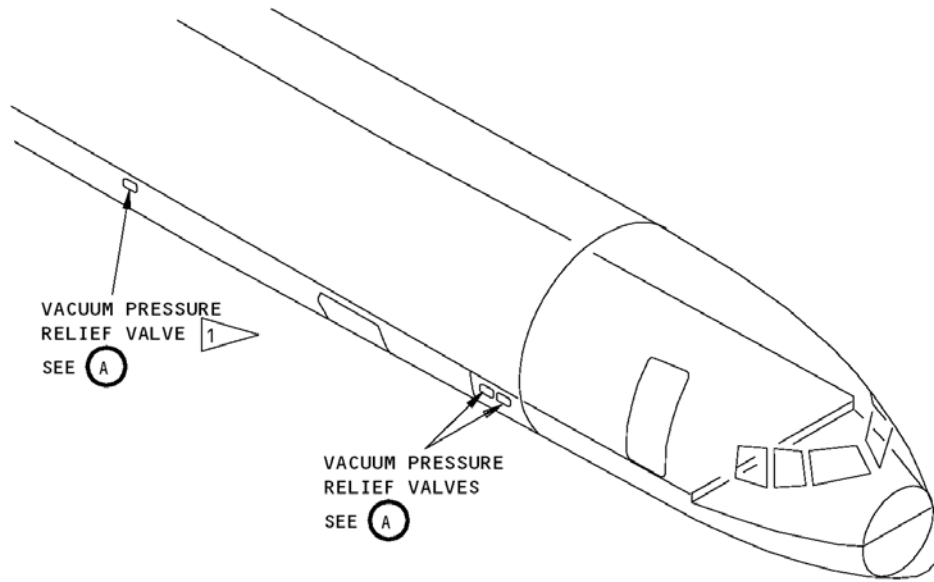

VACUUM PRESSURE RELIEF VALVE

(A)

1 757-300 AIRPLANES

Vacuum Pressure Relief Valve Installation
Figure 1