

# ATA AIRLINES, INC.

BPCU BITE/PERIODIC TEST

PAGE 1 / 3

CHECK BEING PERFORMED: Custom

ZONES: 119 800  
A/C NUMBER:  
REV. DATE: 10/18/04  
FREQUENCY: 4A

W/C NUMBER: 214M2401      DATE:  
W/O:  
JAC CODE:

## PANELS

821

## REFERENCES

1, AMM 06-46-00-2, AMM 24-22-20-2, AMM 25-50-03-4

MECH      INSP

---

MPD REF: 24-22-00-5A

PERFORM BPCU BITE/PERIODIC TEST.

1. BPCU BITE/PERIODIC TEST (Fig. 1).

A. References.

(1) 06-46-00-2, Cargo doors, maintenance practices.

(2) 24-22-00-2, Electrical power, control.

(3) 25-50-03-4, Cargo compartment, bulkhead lining.

B. Prepare for the Test.

XXXXX (1) Supply external power to the main ac buses  
(Ref 24-22-00-2).

NOTE: Use external power to supply the main ac buses.  
Do not use the IDGs, or the APU generator, to  
supply power to these buses.

XXXXX (2) Open forward cargo door, 821 (AMM 06-46-00-2).

(a) Open the E5 rack access panel on fwd bulkhead that  
is fwd of cargo door (AMM 25-50-03-4).

C. Procedure.

XXXXX (1) Do the PERIODIC TEST:

(a) Locate the BPCU on the E5-3 rack and momentarily  
push the PERIODIC TEST switch.

---

REVISION DATE: 10/18/04

ATA AIRLINES, INC. B757 FLEET

W/C #: 214M2401

DATE WORK CARD COMPLETE \_\_\_/\_\_\_/\_\_\_

A/C NUMBER:

CHECK BEING PERFORMED: Cust

W/C NUMBER: 214M2401 (continued)

MECH: INSP:

- | b) EXTERNAL POWER SYSTEM.
- | c) OK.
- | d) LEFT GEN POWER SYSTEM.
- | e) OK.
- | f) RIGHT GEN POWER SYSTEM.
- | g) OK.
- | h) APU GEN POWER SYSTEM.
- | i) OK.
- | j) LAST FLT END OF DATA.
- | k) FOR PREVIOUS FLT PUSH NOW.
- | 1) If it is necessary, show the display again:
  - | a) Stop until the FOR PREVIOUS FLT PUSH NOW indication goes off.
  - | b) Momentarily push the PERIODIC TEST switch.
- | (b) Push the RESET switch on the front of the BPCU.
- | (c) Make sure the indication sequence shows on the BPCU.
  - | 1) EXTERNAL POWER SYSTEM.
  - | 2) LEFT GEN POWER SYSTEM.
  - | 3) RIGHT GEN POWER SYSTEM.
  - | 4) APU GEN POWER SYSTEM.
- | \_\_\_\_\_ XXXXX (2) Close the E5 rack access panel (AMM 25-50-03-4).

BPCU BITE/PERIODIC TEST

PAGE:3 /3

A/C NUMBER:

CHECK BEING PERFORMED: Cust

W/C NUMBER: 214M2401 (continued)

MECH: INSP:

---

| \_\_\_\_ XXXXX (3) Close the forward cargo door, 821 (AMM 06-46-00-2).

| \_\_\_\_ XXXXX (4) Remove electrical power if it is not necessary  
| (Ref 24-22-00-2).

| \*\*\*\*\* END OF WORKCARD \*\*\*\*\*

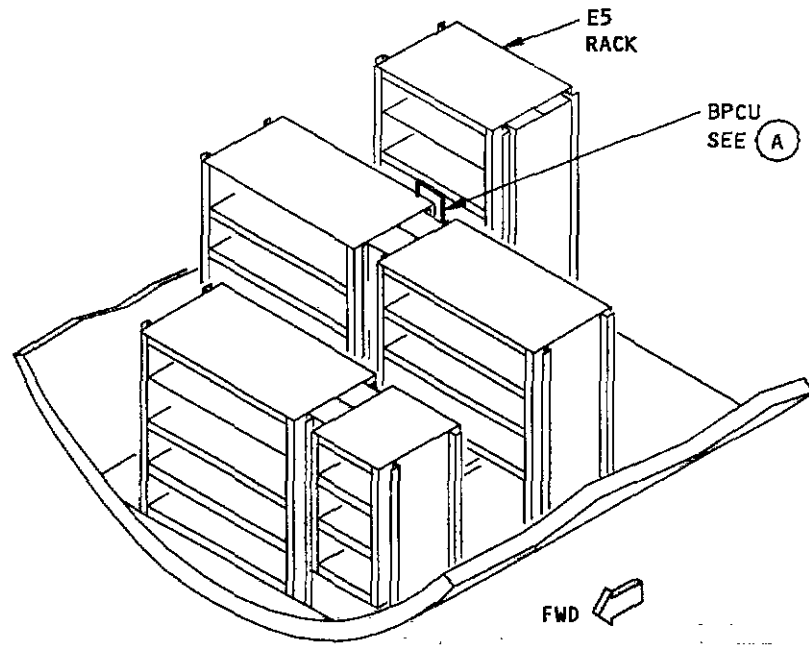

MAIN EQUIP CTR

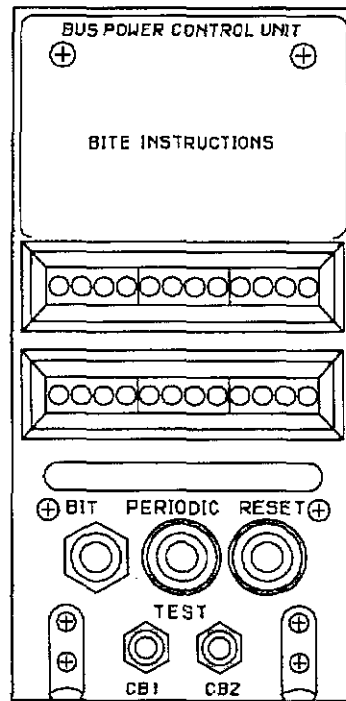

BUS POWER CONTROL UNIT, M116

(A)