

CHECK BEING PERFORMED: Custom

ZONES: 133 134
A/C NUMBER:
REV. DATE: 06/07/06
FREQUENCY: S4C

W/C NUMBER: 215I5304
DATE:
W/O:
JAC CODE:

PANELS

134AZ 134CZ 194ER 1341
134BZ 134DZ 193HL 5002

REFERENCES

1 THROUGH 3 CP57-133(134)-01I

MECH INSP

{CPCP} WING CENTER SECTION INTERNAL

CAUTION: ENSURE THE WING CENTER SECTION TANK HAS BEEN DEFUELED,
SUMPED AND PURGED PRIOR TO TANK ENTRY.

1. PERFORM THE FOLLOWING INTERNAL SURVEILLANCE INSPECTIONS

|XXXX | A. PERFORM AN INTERNAL SURVEILLANCE OF THE ZONES (133 & 134).

|XXXX | B. {CP57-133(134)-01I} INSPECT THE WING CENTER SECTION
INTERIOR, UPPER AND LOWER SURFACES SKINS, STRINGERS, FRONT
AND REAR SPARS, SPANWISE AND LOWER SURFACE BEAMS, AND SIDE
OF BODY RIBS AND SPLICES WITH PARTICULAR ATTENTION TO FRONT
AND REAR SPAR CHORDS AND WEBS. CLEAR ANY BLOCKED HOLES OR
GAPS THAT MAY HINDER DRAINAGE.

FOR CRACKS, PERMANENT DEFORMATION, OR CORROSION TO
PRIMARY STRUCTURE (REF. SRM CHAPTER 51); INITIATE A
SERVICE DIFFICULTY REPORT (SDR) (REF. GMM, CHAPTERS 4, 12,
AND 16) AND RECORD THE ASSOCIATED NON-ROUTINE NUMBERS
BELOW.

Four horizontal lines for recording non-routine numbers.

2. PERFORM THE FOLLOWING DETAILED INTERNAL INSPECTIONS:

|XXXX | A. PERFORM A DETAILED INTERNAL INSPECTION OF THE RIB CHORD,
STRINGER, FITTINGS AND SKIN AT THE WING LOWER SURFACE SIDE
OF BODY SPLICE, WBL 70.5, FROM THE REAR SPAR TO STRINGER S10
BETWEEN WBL 58 AND WBL 70.5.

|XXXX | B. PERFORM A DETAILED INTERNAL INSPECTION OF THE WING LOWER
SURFACE SKIN AND STRINGERS IN THE AREAS OF ATTACHMENTS TO
THE KEEL BEAM CHORD AT BL 7.5 FROM THE REAR SPAR TO STRINGER

A/C NUMBER:

CHECK BEING PERFORMED: Cust

W/C NUMBER: 215I5304 (continued)

MECH: INSP:

S-5.

|XXXX _____ C. PERFORM A DETAILED INTERNAL INSPECTION OF THE WING CENTER SECTION REAR SPAR LOWER CHORD IN AREAS OF ATTACHMENTS BETWEEN LBL 58 AND RBL 58.

|XXXX _____ D. PERFORM A DETAILED INTERNAL INSPECTION OF THE WING CENTER SECTION REAR SPAR TERMINAL FITTING AND ADJACENT REAR SPAR (CHORDS AND WEBS) BETWEEN SIDE OF BODY SPLICE, WBL 70.5 AND WBL 58.

|XXXX _____ E. PERFORM A DETAILED INTERNAL INSPECTION OF THE WING CENTER SECTION OF BODY RIBS FROM REAR SPAR TO SPAN-WISE BEAM NUMBER 2.

|XXXX _____ F. PERFORM A DETAILED INTERNAL INSPECTION OF THE WING CENTER SECTION LOWER SPLICE STRINGER S-5 FROM LBL 58 TO RBL 58.

*****END OF WORKCARD*****

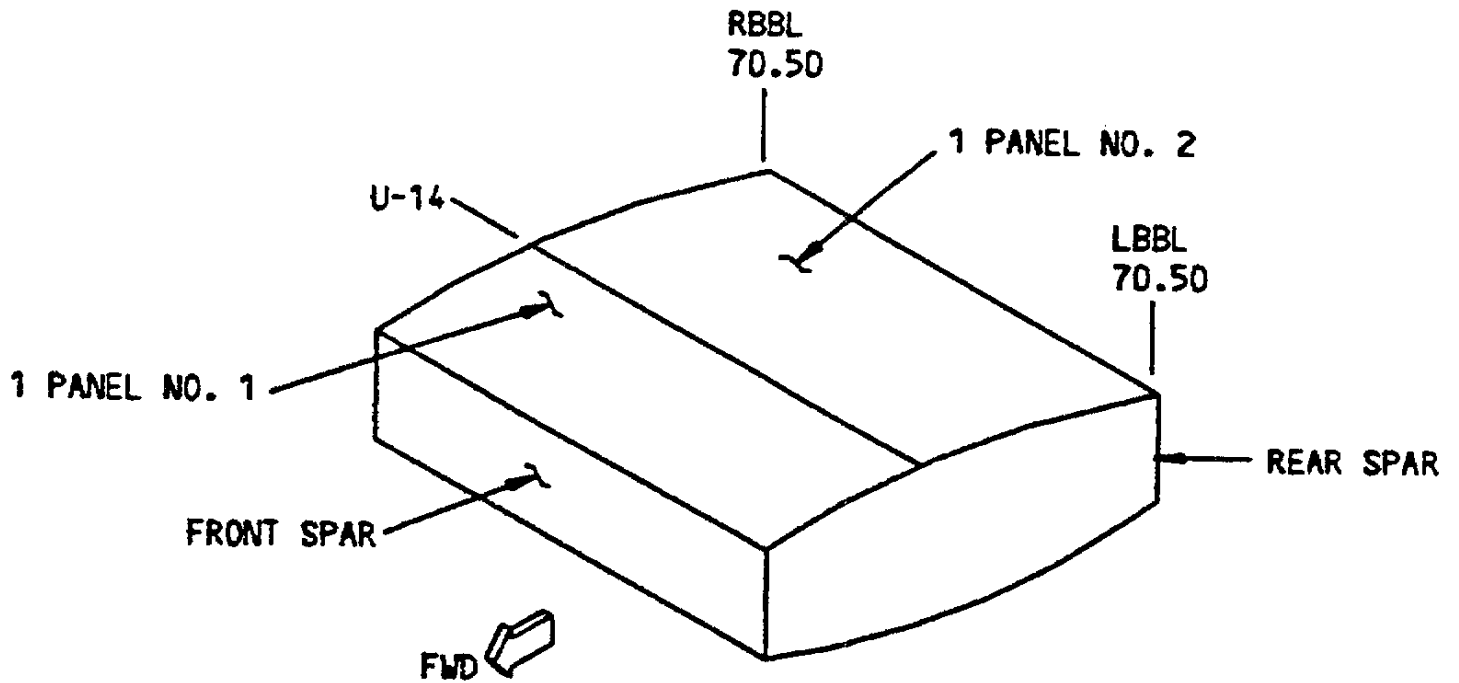

UPPER SKIN PANELS
DETAIL I

CENTER WING SKIN

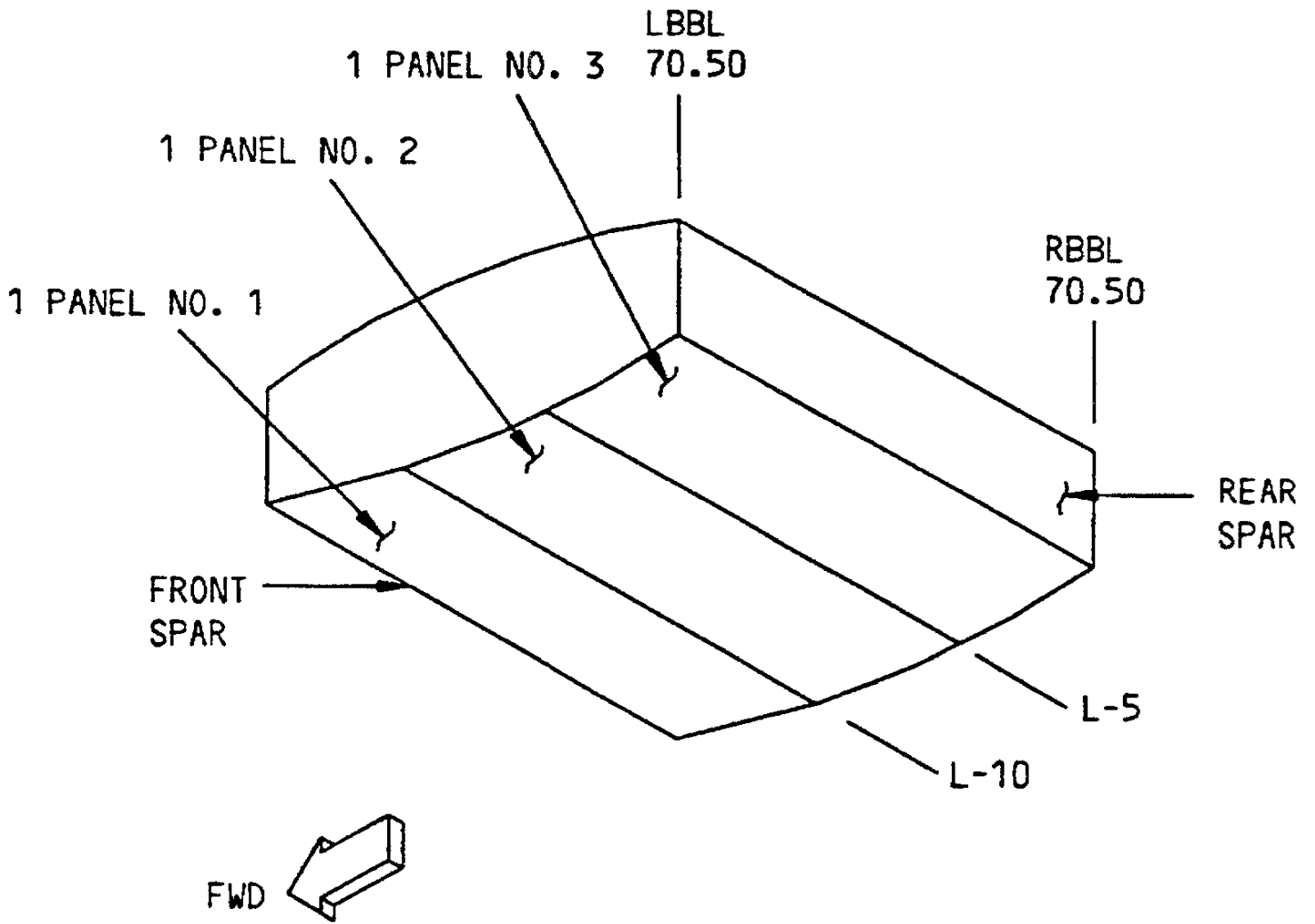

LOWER SKIN PANELS
DETAIL II

CENTER WING SKIN

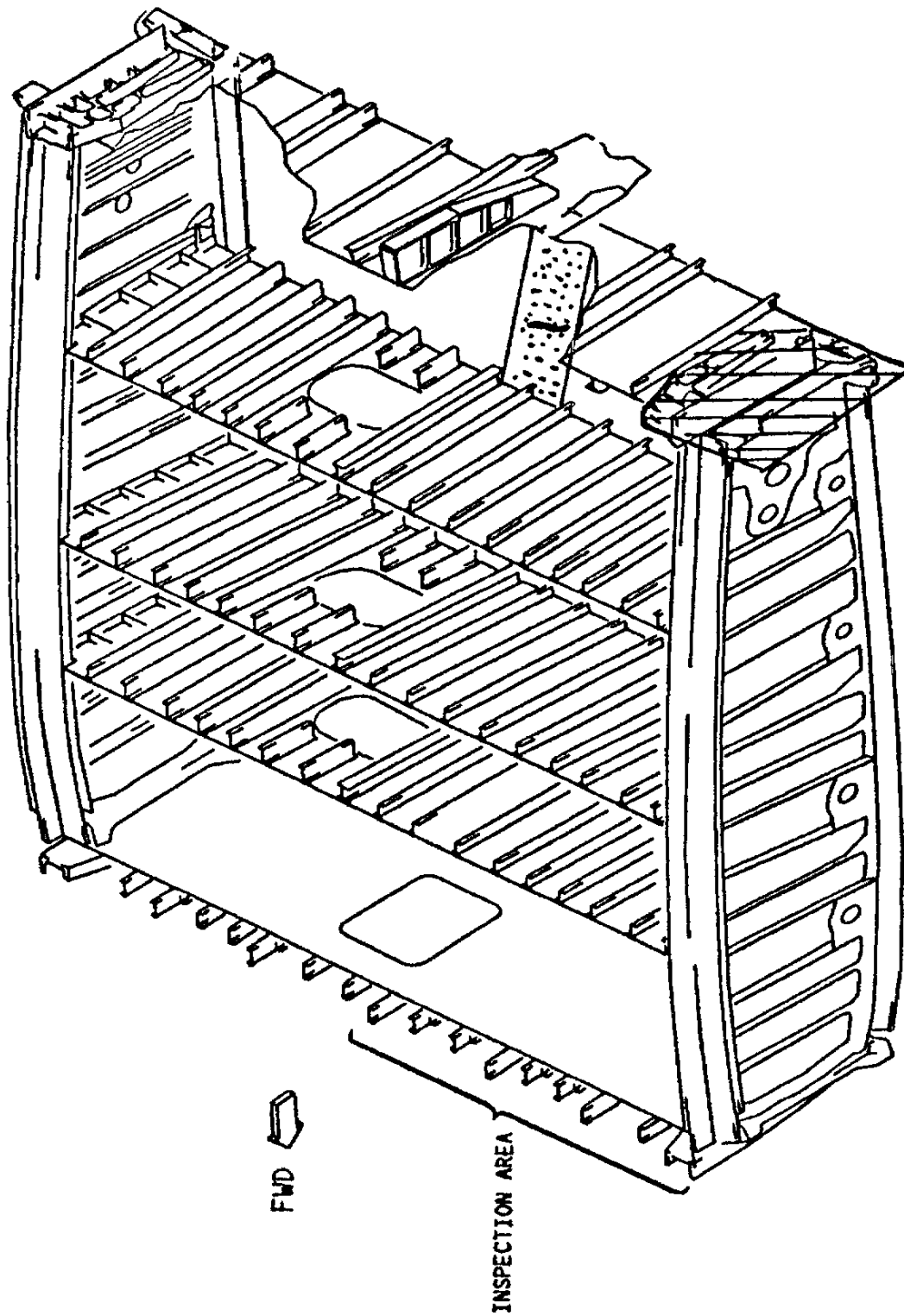

STRUCTURE

FIGURE 3

08/06/1998