

ATA AIRLINES, INC.

STABILIZER TAKEOFF WARNING SYSTEM

PAGE 1 / 3

CHECK BEING PERFORMED: Custom

ZONES: 211
A/C NUMBER:
REV. DATE: 11/16/04
FREQUENCY: 1C

W/C NUMBER: 221M2703
DATE:
W/O:
JAC CODE:

REFERENCES

1, 2

MECH INSP

OPERATIONALLY CHECK STABILIZER TAKEOFF WARNING SYSTEM.

1 Stabilizer Takeoff Warning System - Operational Test

A General

1 No ground support equipment is necessary to do the operational test for the stabilizer takeoff warning system.

B References

- 1 24-22-00/201, Electrical Power - Control
- 2 29-11-00/201, Main (Left, Right, Center) Hydraulic Systems

C Stabilizer Takeoff Warning Test (Fig. 1, 2).

- _____ XXXXX 1 Supply electrical power (Ref 24-22-00/201).
- _____ XXXXX 2 Make sure these circuit breakers on the P11 panel are closed:

NOTE: AIRPLANES WITH ALTERNATE STAB TRIM SWITCHES ON THE CONTROL STAND;

- a 11B19, STAB TRIM ALT
- b 11C12, STAB TRIM SHUTOFF LEFT
- C 11C13, STAB TRIM SHUTOFF RIGHT

- _____ XXXXX 3 Make sure that the RIGHT and CENTER STAB TRIM SHUTOFF valve switches on the P10 panel are in NORM.

WARNING: KEEP PERSONS AND EQUIPMENT AWAY FROM ALL CONTROL SURFACES WHEN HYDRAULIC POWER IS SUPPLIED. AILERONS, ELEVATORS, RUDDER, FLAPS, SLATS,

STABILIZER TAKEOFF WARNING SYSTEM

A/C NUMBER:

CHECK BEING PERFORMED: Cust

W/C NUMBER: 221M2703 (continued)

MECH: INSP:

SPOILERS, AND STABILIZER ARE FULLY POWERED SURFACES. INJURY TO PERSONS OR DAMAGE TO EQUIPMENT CAN OCCUR WHEN HYDRAULIC POWER IS SUPPLIED.

- XXXXX 4 Pressurize the left, right and center hydraulic systems (Ref 29-11-00/201).
XXXXX 5 Move the flap lever to the 20-unit detent.
XXXXX 6 Move the horizontal stabilizer such that it is between 2.0 and 7.0 units of trim on the stabilizer trim position indicators (greenband range).
XXXXX 7 Release the parking brake.
XXXXX 8 Push and hold the takeoff warning test switch on the right sidewall panel, P61, for the full test.
XXXXX 9 Make sure that the indications that follow do not come on:

NOTE: Some nuisance messages can show on the EICAS display. These messages are not important for this test.

- a Red CONFIG light on the pilot's center instrument panel, P2.
b Captain's and first officer's master warning lights on the glareshield panel, P7.
c EICAS red warning message (STABILIZER).
d Aural warning siren.

- XXXXX 10 Move the stabilizer trim control when switches up until the stabilizer is just out of the greenband range.
XXXXX 11 Make sure that the indications that follow, do come on:
a Red CONFIG light on the P2 panel.
b Captain's and first officer's master warning lights

STABILIZER TAKEOFF WARNING SYSTEM

A/C NUMBER:

CHECK BEING PERFORMED: Cust

W/C NUMBER: 221M2703 (continued)

MECH: INSP:

on the P7 panel.

c EICAS red warning message (STABILIZER).

d Aural warning siren.

_____ XXXXX 12 Move the horizontal stabilizer such that it is between 2.0 and 7.0 units of trim on the stabilizer trim position indicator (greenband range).

_____ XXXXX 13 Make sure that all of the warnings stop as soon as the stabilizer moves into the greenband range.

_____ XXXXX 14 Move the stabilizer trim control wheel switches down until the horizontal stabilizer is just out of the greenband range.

_____ XXXXX 15 Make sure that the indications that follow, do come on:
a Red CONFIG light on the P2 panel.
b Captain's and first officer's master warning lights on the P7 panel.
c EICAS red warning message (STABILIZER)
d Aural warning siren.

_____ XXXXX 16 Move the horizontal stabilizer such that it is between 2.0 and 7.0 units of trim on the stabilizer trim position indicator (greenband range).

_____ XXXXX 17 Make sure that all of the warnings stop as soon as the horizontal stabilizer moves into the greenband range.

_____ XXXXX 18 Release the takeoff warning test switch on the P61 panel.

_____ XXXXX 19 Set the parking brake.

_____ XXXXX 20 Remove the power from the left, right and center hydraulic systems (Ref 29-11-00/201).

STABILIZER TAKEOFF WARNING SYSTEM

PAGE:4 /3

A/C NUMBER:

CHECK BEING PERFORMED: Cust

W/C NUMBER: 221M2703 (continued)

MECH: INSP:

| ____ XXXXX 21 Remove electrical power as required (Ref 24-22-00/201).
*****END OF WORKCARD*****

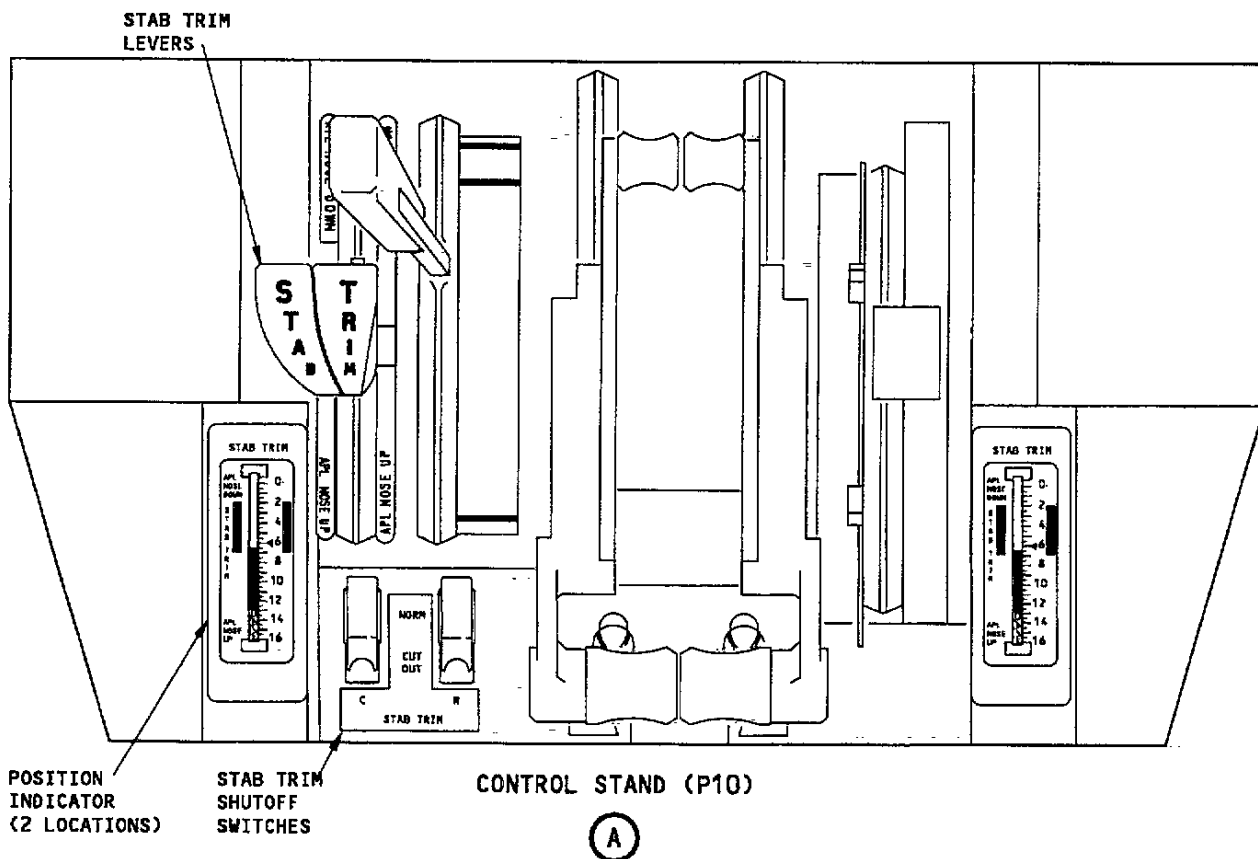
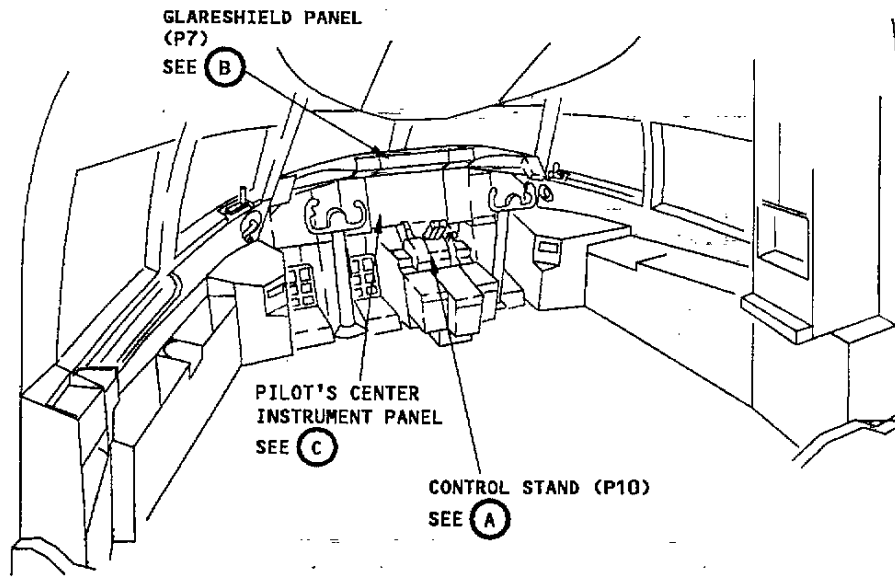

Horizontal Stabilizer Trim Control System

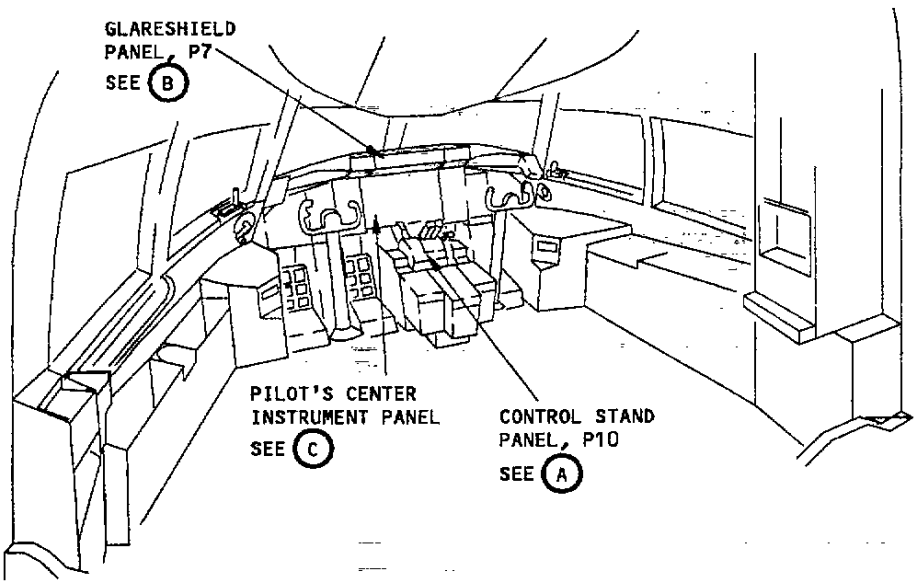

ALTERNATE STABILIZER TRIM SWITCHES

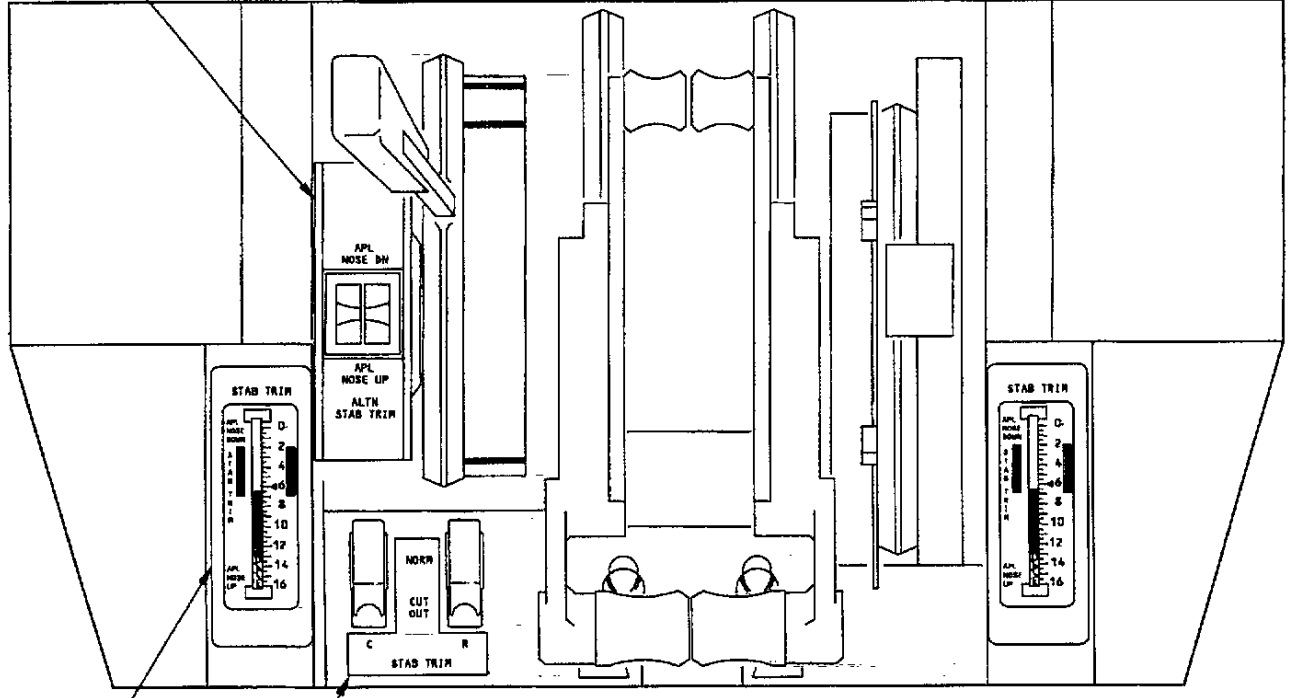

POSITION INDICATOR (2 LOCATIONS)

STABILIZER TRIM SHUTOFF SWITCHES

CONTROL STAND PANEL, P10

(A)

Horizontal Stabilizer Trim Control System