

CHECK BEING PERFORMED: Custom

ZONES: 313 314  
 A/C NUMBER:  
 REV. DATE: 06/06/06  
 FREQUENCY: 1C

W/C NUMBER: 231M2601  
 DATE:  
 W/O:  
 JAC CODE:

PANELS

313AL

REFERENCES

1  
 MECH INSP

MPD TASK 26-22-01-4A

CHECK APU FIRE EXTINGUISHER BOTTLE SQUIB CARTRIDGES FOR EXPIRATION.

NOTE: Ref. GMM Chapter 8 Shelf Life Requirements

NOTE: Squib located on FWD side of the APU firewall.

XXXXX \_\_\_\_\_ 1. Record the following information from the active APU fire extinguisher squib tag and ensure squib life will not expire within the next 20 months:

NOTE: If squib part number is not listed in Table 1 below, contact Systems Engineering for Effectivity, Total Life and Service Life.

TABLE 1

\*\*\*\*\*

EFF	PART NUMBER	DESCRIPTION	TOTAL LIFE (YRS)	SERVICE LIFE (YRS)*
-200	30903859	APU SQUIB	15	10
-300	446189-1	APU SQUIB	10	10
	262299	APU SQUIB	10	10
	262299-1	APU SQUIB	10	10
	262299-2	APU SQUIB	10	10

\* Service Life begins when the squib is installed on a fire extinguisher bottle. Full service life may be utilized only if total is not exceeded.

\*\*\*\*\*

A/C NUMBER:

CHECK BEING PERFORMED: Cust

W/C NUMBER: 231M2601 (continued)

MECH: INSP:

---

WARNING: DO NOT TOUCH THE SQUIB BEFORE PERFORMING PROCEDURES INVOLVING DEVICES SENSITIVE TO ELECTROSTATIC DISCHARGE. ELECTROSTATIC DISCHARGE CAN CAUSE THE FIRE BOTTLE TO RELEASE ITS CONTENTS SUDDENLY, AND CAN CAUSE INJURY TO PERSONS AND DAMAGE TO EQUIPMENT. (REF GMM CHAPTER 3)

A. Part Number: \_\_\_\_\_

B. Serial Number: \_\_\_\_\_

C. Date of Manufacture: \_\_\_\_\_

D. Installation Date: \_\_\_\_\_

NOTE: If Installation Date is not listed on metal squib information tag, installation date will be the same as manufacture date. If the tag is missing or illegible, generate a non-routine to have a new tag made IAW EO 757-26ID-2469.

NOTE: Some squibs do not contain serial numbers. Mark "Serial Number" blank as N/A if serial number is not available.

E. Use the two formulas listed below to determine the squib expiration date. Expiration date is the earlier of the two dates calculated. Record expiration date below.

\_\_\_\_\_ + \_\_\_\_\_ = \_\_\_\_\_  
 Date of Manufacture      Total Life      Date

\_\_\_\_\_ + \_\_\_\_\_ = \_\_\_\_\_  
 Installation Date      Service Life      Date

Expiration Date: \_\_\_\_\_

F. If current date is 20 months or less from expiration date, generate a non-routine for squib removal and replacement. Record the following information for the REPLACEMENT squib and ensure information is properly etched on ID tag.

APU FIRE EXTINGUISHER BOTTLE SQUIB CARTRIDGES

A/C NUMBER:

CHECK BEING PERFORMED: Cust

W/C NUMBER: 231M2601 (continued)

MECH: INSP:

---

| (1) Part Number: \_\_\_\_\_

| (2) Serial Number: \_\_\_\_\_

| (3) Date of Manufacture: \_\_\_\_\_

| (4) Installation Date: \_\_\_\_\_

| NOTE: N/A information blanks in step 1.F. if  
| squib replacement is not required.

\*\*\*\*\* END OF WORKCARD \*\*\*\*\*

231M2601

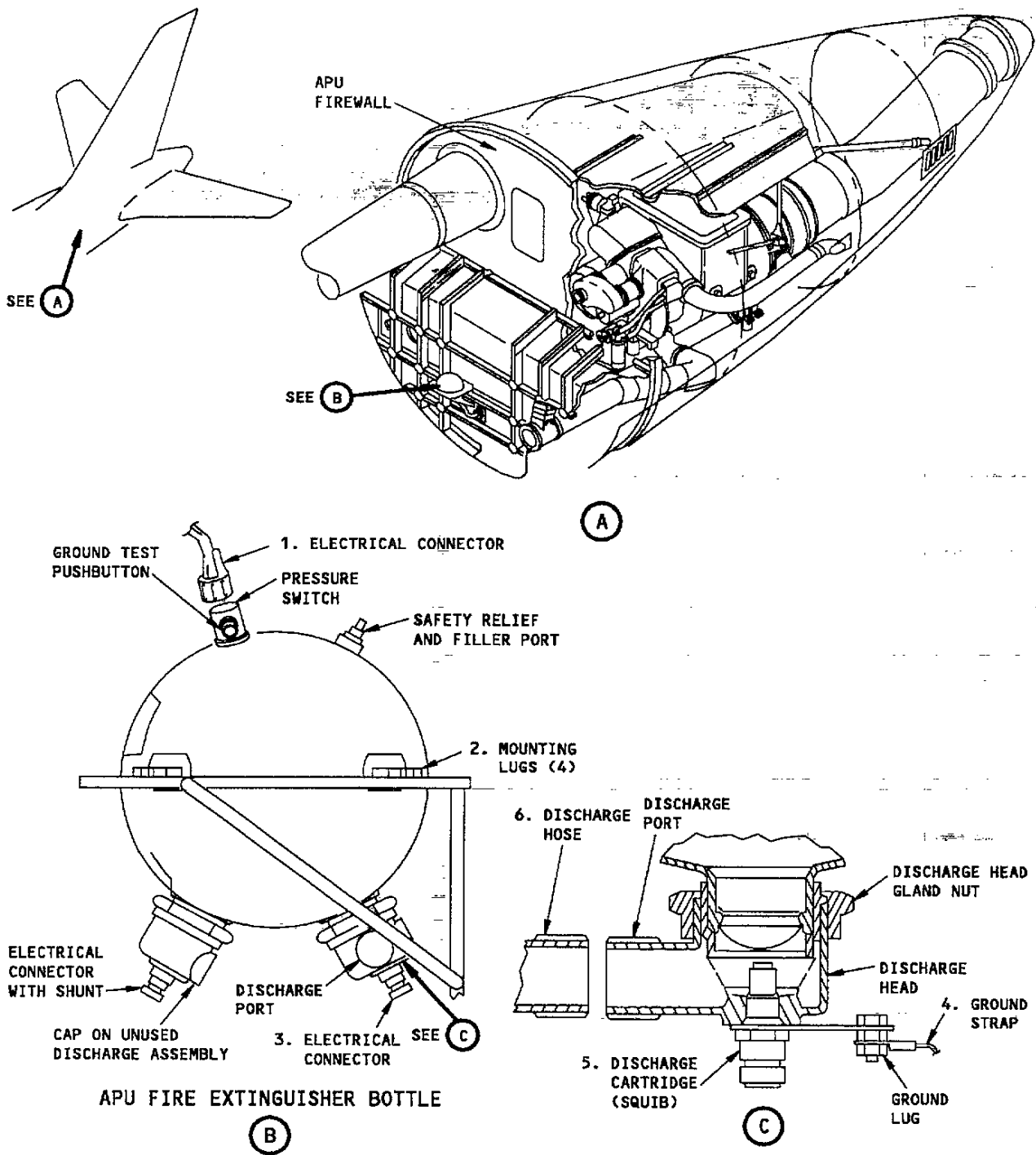

APU Fire Extinguisher Bottle/Discharge Cartridge Installation