

ATA AIRLINES, INC.

RESTORE VACUUM BLOWER FILTER

PAGE 1 / 3

CHECK BEING PERFORMED: Custom

ZONES: 100
A/C NUMBER:
REV. DATE: 01/29/03
FREQUENCY: 4A

W/C NUMBER: 312R3801 DATE:

MFR P/N	DESCRIPTION	QTY
S9026G221	Packing	4
606338-1	Filter Assy - Air	A/R

TOOLS	DESCRIPTION	QTY
COMMON	Regulated Air Source, Dry Filtered, 0-30psi (Commercially Available)	1

PANELS

822
S1401

REFERENCES

FIGURES 1 AND 2, AMM 24-22-00, 25-52-20, 38-32-05

MECH INSP

CLEAN OR REPLACE THE VACUUM BLOWER FILTER (AS REQUIRED).

1. Vacuum Blower Filter Cleaning or Replacement
(Figures 1 and 2).

_____ XXXXX A. Prepare for the Removal

- (1) Open the Aft Cargo Door, 822.
- (2) Do this task: Waste Tank Enclosure Panel Removal
(AMM TASK 25-52-20-000-801 p401).

WARNING: BE CAREFUL WHEN YOU ACCESS THE (ROW F) CIRCUIT BREAKERS ON THE INSIDE OF THE P91 AND P92 PANELS. IF POSSIBLE, REMOVE AIRPLANE ELECTRICAL POWER BEFORE YOU ACCESS THE INSIDE OF THE P91 AND P92 PANELS. THE P91 AND P92 PANELS CONTAIN HIGH VOLTAGES AND CURRENTS THAT MAY CAUSE INJURIES TO PERSONS.

- (3) Open these circuit breakers and attach DO-NOT-CLOSE tags:

(a) Power Distribution Panel Number 1, P91:

- 1) 91C11 VACUUM WASTE CONT
- 2) 91F2 VACUUM WASTE BLOWER

A/C NUMBER:

CHECK BEING PERFORMED: Cust

W/C NUMBER: 312R3801 (continued)

MECH: INSP:

_____ XXXXX B. Vacuum Blower Filter Removal

- (1) Remove and then discard the packings [31] that attach the vacuum blower filter assy [32] to the vacuum blower.
- (2) Remove the vacuum blower filter assy [32] from the vacuum blower.

_____ XXXXX C. Vacuum Blower Filter Cleaning

- (1) Clean the vacuum blower filter assy [32] with an air source (0-30 psig) in the opposite direction of the usual flow.
- (2) Do a check of the vacuum blower filter assy [32] for damage or signs of worn areas.
 - (a) If the vacuum blower filter assy [32] has damage or signs of worn areas, use a new vacuum blower filter assy [32].
 - (b) If the vacuum blower filter assy [32] is serviceable, then continue.

_____ XXXXX D. Vacuum Blower Filter Installation

- (1) Put the vacuum blower filter assy [32] in its position.
- (2) Install the packings [31] that attach the vacuum blower filter assy [32] to the vacuum blower.

_____ XXXXX E. Vacuum Blower Filter Installation Test

WARNING: BE CAREFUL WHEN YOU ACCESS THE (ROW F) CIRCUIT BREAKERS ON THE INSIDE OF THE P91 AND P92 PANELS. IF POSSIBLE, REMOVE AIRPLANE ELECTRICAL POWER BEFORE YOU ACCESS THE INSIDE OF THE P91 AND P92 PANELS. THE P91 AND P92 PANELS CONTAIN HIGH VOLTAGES AND CURRENTS THAT MAY CAUSE INJURIES TO PERSONS.

- (1) Close these circuit breakers:

A/C NUMBER:

CHECK BEING PERFORMED: Cust

W/C NUMBER: 312R3801 (continued)

MECH: INSP:

(a) Power Distribution Panel Number 1, P91:

1) 91C11 VACUUM WASTE CONT

2) 91F2 VACUUM WASTE BLOWER

(2) Do this task: Supply Electrical Power
(AMM TASK 24-22-00-860-811 p201).

(3) Make sure the vacuum blower operates as follows:

(a) Make sure the vacuum blower starts when you
push the flush switch for a toilet.

NOTE: If the vacuum blower operates before
you push the flush switch, there is a
problem in the control circuits.

(b) Make sure the vacuum blower stops after
approximately 15 seconds.

NOTE: If the vacuum blower continues to
operate after approximately 15 seconds,
there is a problem in the control
circuits.

_____ XXXXX F. Put the Airplane Back to Its Usual Condition

WARNING: SEAL THE CARGO COMPARTMENT WITH THE LINING.
OBEY THE INSTRUCTIONS IN THE SPECIFIED
PROCEDURE WHEN YOU INSTALL THE LINING. IF YOU
INSTALL THE LINING INCORRECTLY, THE FIRE
EXTINGUISHING AGENT OR SMOKE CAN GET INTO THE
PASSENGER COMPARTMENT DURING A FIRE.

(1) Do this task: Waste Tank Enclosure Panel
Installation (AMM TASK 25-52-20-400-801 p401).

(2) Close the Aft Cargo Door, 822.

*****END OF WORKCARD*****

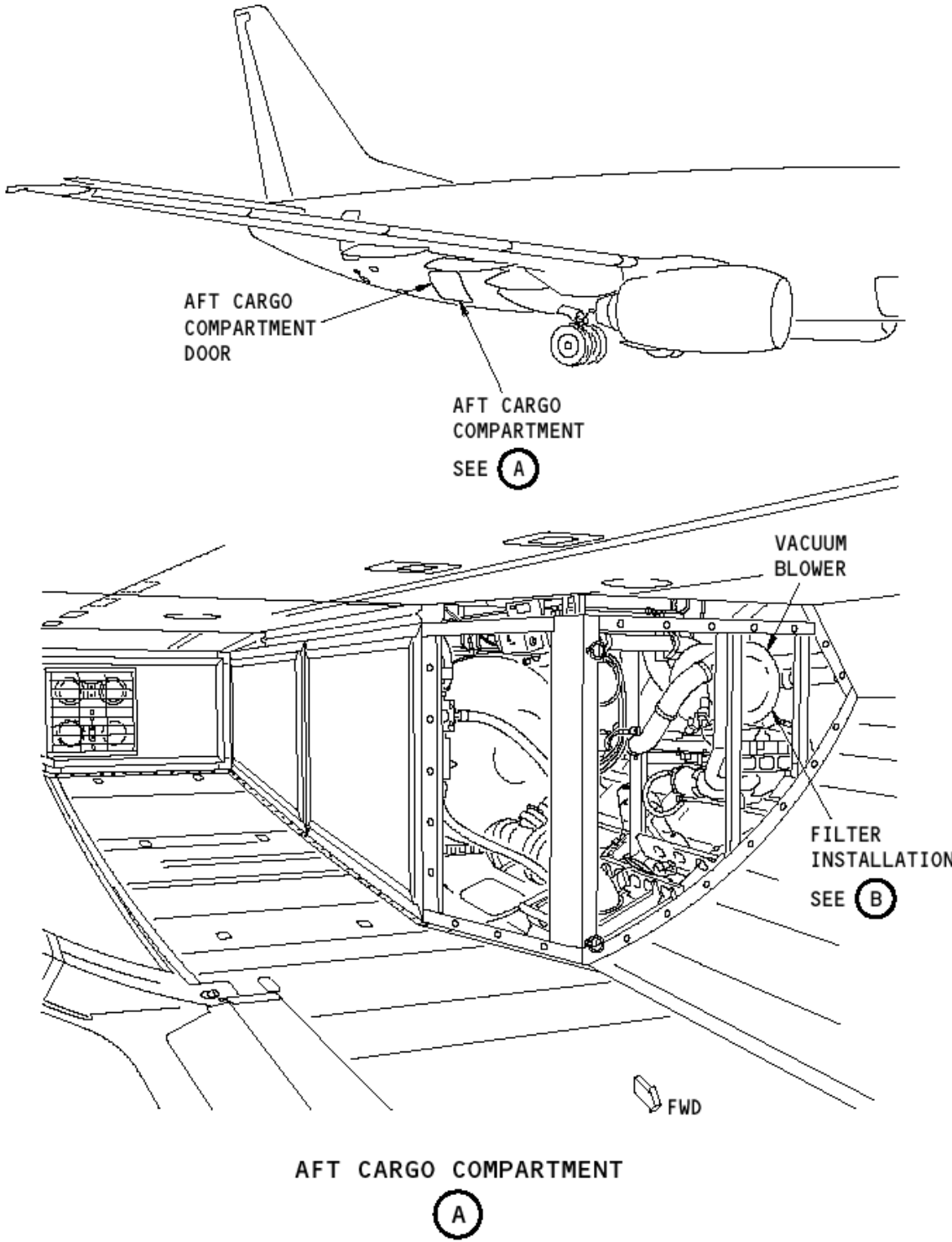

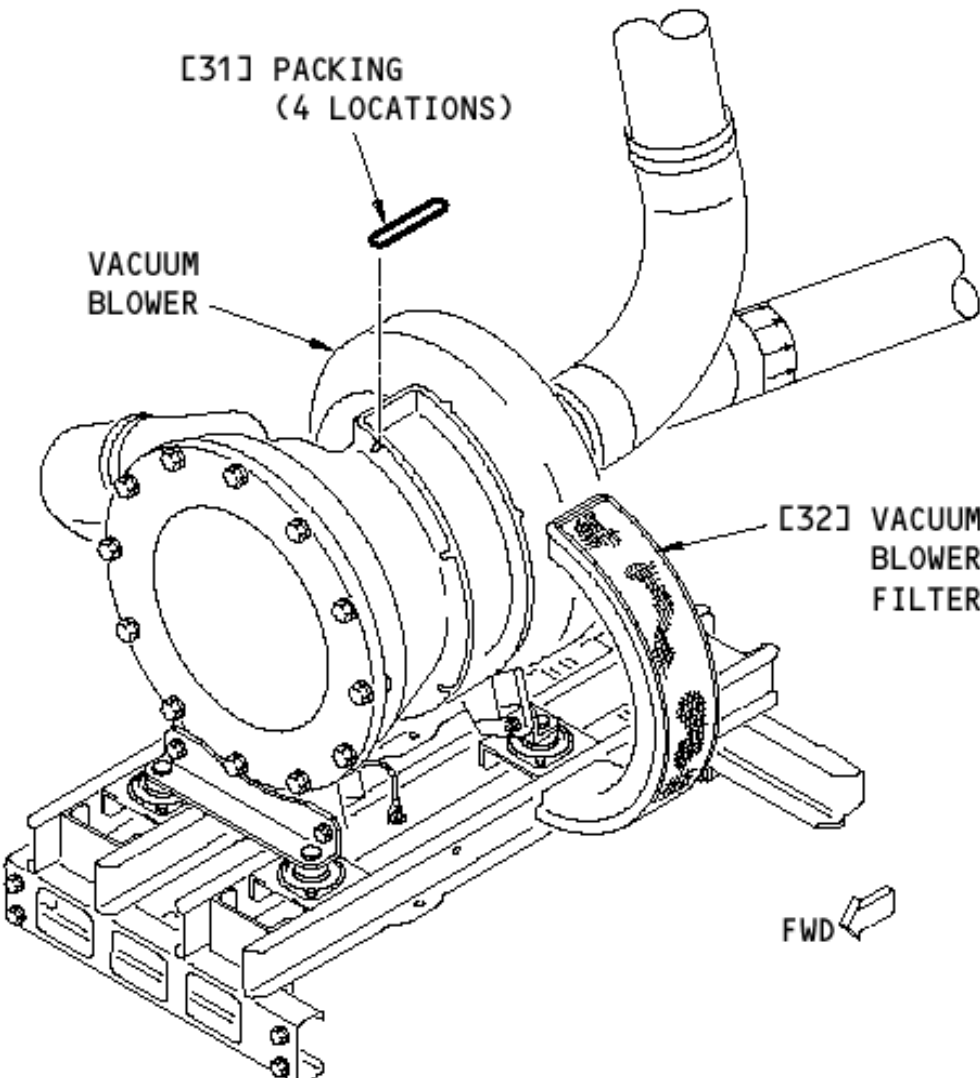

FILTER INSTALLATION

B