

ATA AIRLINES, INC.

EMDP CASE DRAIN FILTER

PAGE 1 / 4

CHECK BEING PERFORMED: Custom

ZONES: 100
A/C NUMBER:
REV. DATE: 01/29/03
FREQUENCY: 1A

W/C NUMBER: 318R2901 DATE:

MFR P/N	DESCRIPTION	QTY
7577741	Filter - Element	1
NAS1611-114	Packing	1
NAS1611-220	Packing	1
BMS3-11	Fluid, Hydraulic, Fire Resistant, Type IV	A/R

REFERENCES

FIGURES 1 THROUGH 3, AMM 12-12-00, 24-22-00, 29-11-00, 29-11-01, 29-11-41

MECH INSP

REPLACE THE "B" HYDRAULIC SYSTEM ELECTRIC MOTOR DRIVEN PUMP (EMDP) CASE DRAIN FILTER.

1. "B" System EMDP Case Drain Filter Element Removal (Figures 1 through 3).

_____ XXXXX A. Prepare for the Removal

WARNING: BE CAREFUL WHEN YOU ACCESS THE (ROW F) CIRCUIT BREAKERS ON THE INSIDE OF THE P91 PANEL. IF POSSIBLE REMOVE AIRPLANE ELECTRICAL POWER BEFORE YOU ACCESS THE CIRCUIT BREAKERS ON THE INSIDE OF P91 PANEL. THE P91 PANEL CONTAINS HIGH VOLTAGES AND CURRENTS THAT MAY CAUSE INJURIES TO PERSONS.

- (1) Open this circuit breaker and attach DO-NOT-CLOSE tag:

(a) Power Distribution Panel Number 1, P91:

1) 91C8 ELEC HYD PUMP CONTROL SYS B

- (2) Remove hydraulic power from hydraulic system B. To remove it, do this task: Hydraulic System A or B Power Removal (AMM TASK 29-11-00-860-805 p201).
- (3) Remove pressure from the hydraulic system B reservoir. To remove it, do this task: Hydraulic Reservoirs Depressurization (AMM TASK 29-11-01-860-802 p201).

_____ XXXXX B. Procedure

- (1) Remove the filter bowl [13] from the filter head.

REVISION DATE: 01/29/03

ATA AIRLINES, INC. B737-800 FLEET

W/C #: 318R2901

DATE WORK CARD COMPLETE ___/___/___

NOTE: Remove the filter [12] with the filter bowl [13].

(a) Put a container below the filter bowl [13] to catch any hydraulic fluid.

(2) Remove the filter [12] from the filter bowl [13].

(3) Remove the packing [9] from the filter [12].

(4) Remove the packing [11], and the backup rings [10] from the filter head.

(5) Look for metal contamination on the filter [12] and in the filter bowl [13].

(a) If you find metal contamination, do this task:
EMDP Case Drain Filter - Metal Contamination
Check (AMM TASK 29-11-41-700-801 p401).

(6) Clean the filter bowl [13].

2. EMDP Case Drain Filter Element Installation
(Figures 1 through 3).

_____ XXXXX A. Procedure

(1) Lubricate the two backup rings [10] and the new packing [11] with fluid, BMS3-11, TYPE IV.

(2) Install the two backup rings [10] and the new packing [11] in the filter head.

(3) Lubricate the new packing [9] with fluid, BMS3-11, TYPE IV.

(4) Install the new packing [9] in the filter [12].

(5) Put the filter [12] in the filter bowl [13].

(6) Lubricate the threads of the filter bowl [13] with fluid, BMS3-11, TYPE IV.

A/C NUMBER:

CHECK BEING PERFORMED: Cust

W/C NUMBER: 318R2901 (continued)

MECH: INSP:

(7) Put the filter bowl [13] and filter [12] under the filter assembly [6].

(a) Raise the filter [12] from the filter bowl [13] and push it onto the filter assembly outlet.

(8) Install the filter bowl [13] on the filter head.

(a) Tighten the filter bowl [13] to 96-120 pound-inches (10.8 - 13.6 newton-meters) pound-inches.

(9) Install lockwire on the filter bowl [13]. To install it, do this task: Lockwires Installation (AMM TASK 20-10-44-400-801 p401).

_____ XXXXX B. EMDP Case Drain Filter Element Installation Test

(1) If it is necessary, do this task: Hydraulic Reservoir Servicing (AMM TASK 12-12-00-610-801 p301).

(2) Pressurize the B system hydraulic reservoir. To pressurize it, do this task: Hydraulic Reservoirs Pressurization (AMM TASK 29-11-01-860-801 p201).

WARNING: BE CAREFUL WHEN YOU ACCESS THE (ROW F) CIRCUIT BREAKERS ON THE INSIDE OF THE P91 PANEL. IF POSSIBLE REMOVE AIRPLANE ELECTRICAL POWER BEFORE YOU ACCESS THE CIRCUIT BREAKERS ON THE INSIDE OF P91 PANEL. THE P91 PANEL CONTAINS HIGH VOLTAGES AND CURRENTS THAT MAY CAUSE INJURIES TO PERSONS.

(3) Remove the DO-NOT-CLOSE tag and close this circuit breaker:

(a) Power Distribution Panel Number 1, P91:

1) 91C8 ELEC HYD PUMP CONTROL SYS B

(4) Do this task: Supply Electrical Power (AMM TASK 24-22-00-860-811 p201).

EMDP CASE DRAIN FILTER

PAGE:4 /4

A/C NUMBER:

CHECK BEING PERFORMED: Cust

W/C NUMBER: 318R2901 (continued)

MECH: INSP:

- (5) Pressurize hydraulic system B with the EMDP.
To pressurize the system, do this task: Hydraulic System Pressurization with an Electric Motor-Driven Pump (EMDP) (AMM TASK 29-11-00-860-803 p201).
- (6) Make sure the B system EMDP operates.
- (7) Make sure the case drain filter assembly [6] does not have leaks.

*****END OF WORKCARD*****

REVISION DATE: 01/29/03

ATA AIRLINES, INC. B737-800 FLEET

W/C #: 318R2901

DATE WORK CARD COMPLETE ___/___/___

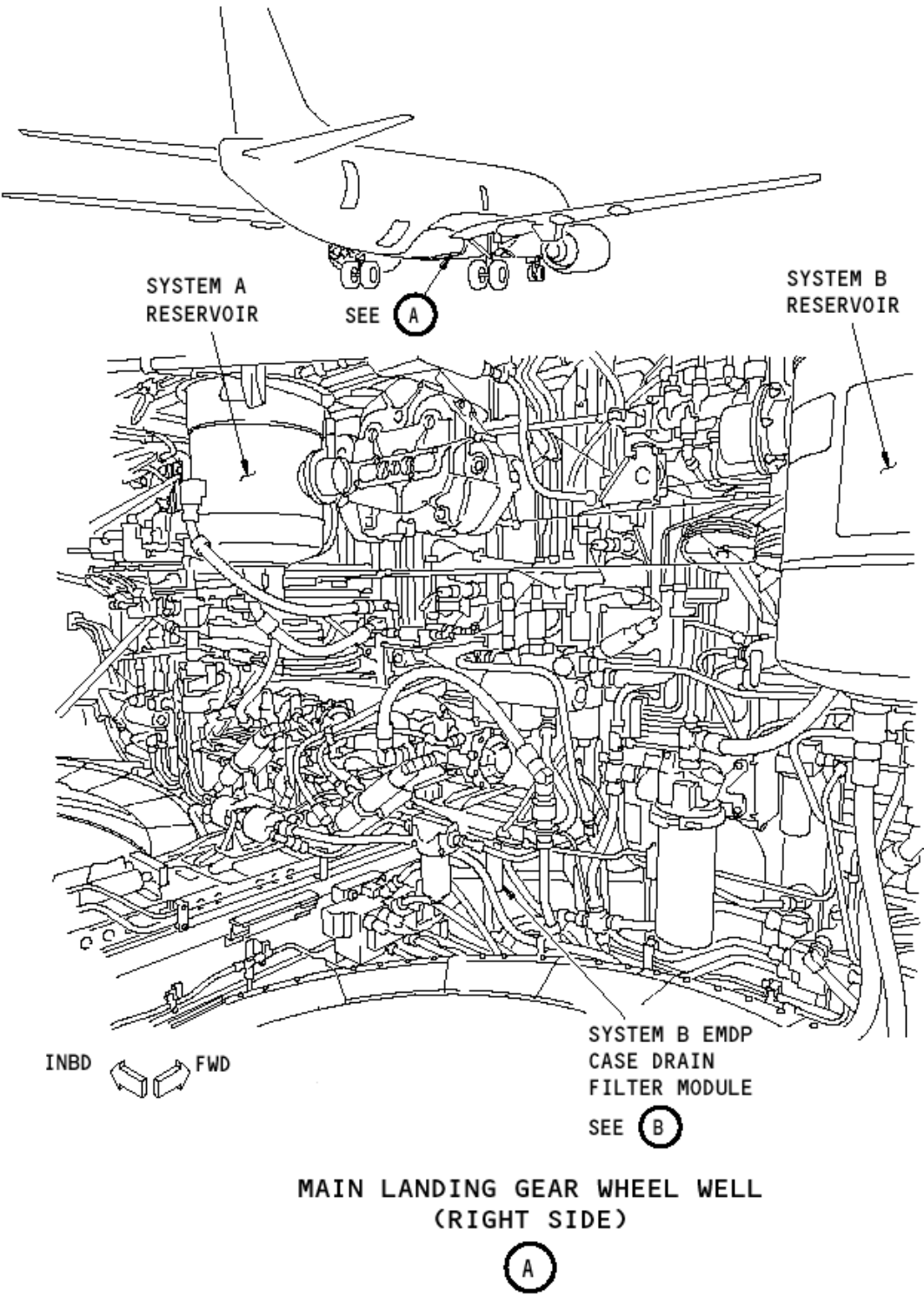

B System EMDP Case Drain Filter

FIGURE 1

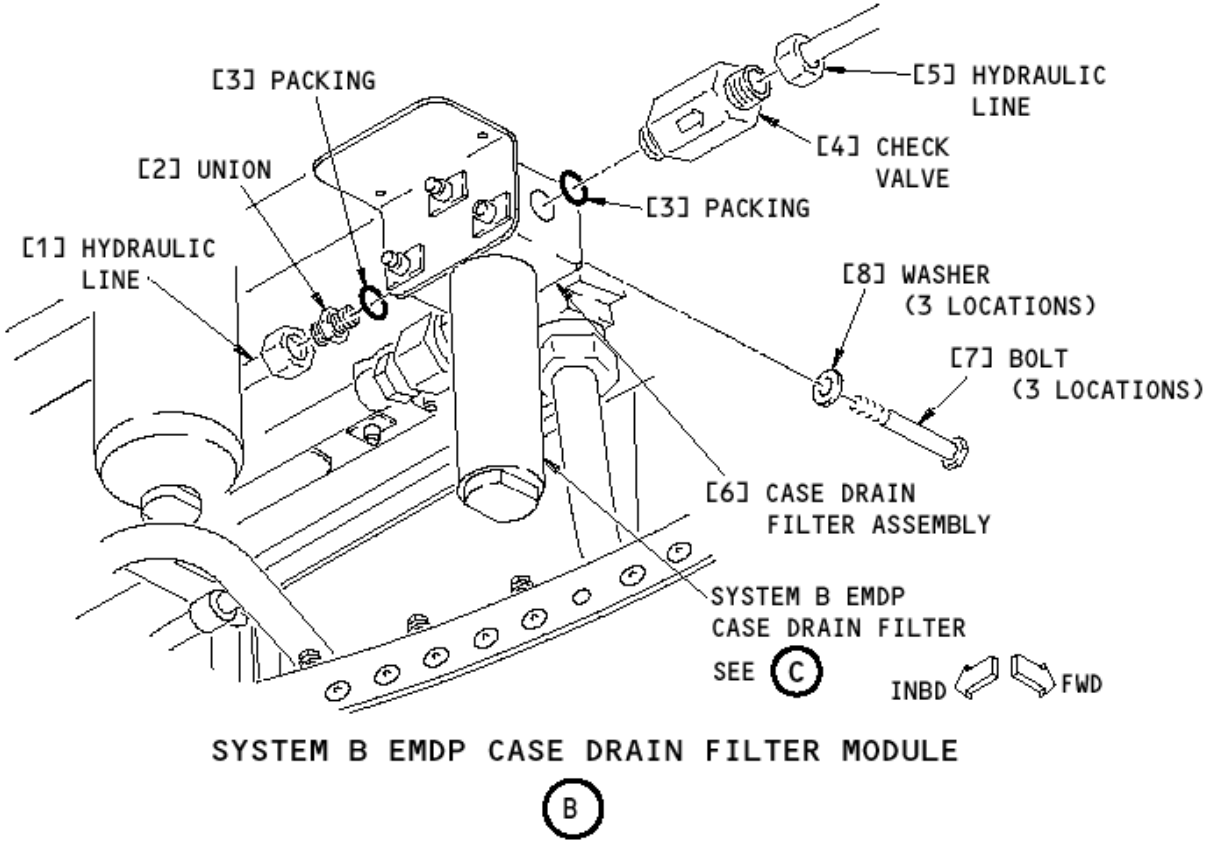

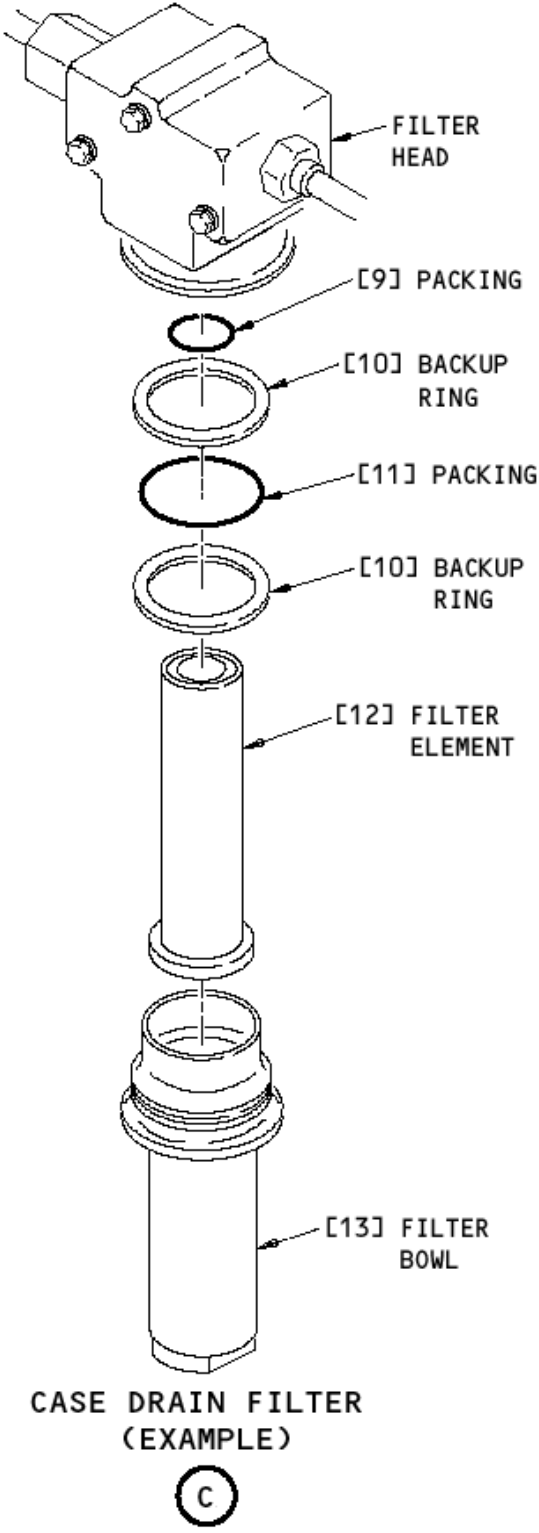

CASE DRAIN FILTER
(EXAMPLE)

(C)