

**ATA AIRLINES, INC.**

ADJUSTMENT HOLES IN CAPTAINS/FIRST OFFICERS SEAT TRACKS

PAGE 1 / 2

CHECK BEING PERFORMED: Custom

ZONES: 200  
A/C NUMBER:  
REV. DATE: 05/25/06  
FREQUENCY: 8A

W/C NUMBER: 321I2502      DATE:

TOOLS	DESCRIPTION	QTY
A25020-8	Gage - Inspection, Seat Track, Flight Crew Seats	1

**REFERENCES**

Figures 1, 2

**MECH      INSP**

---

MPD ITEM: 25-010-01, 25-010-02

NOTE: Kit P/N A25020-8 required for this workcard contains  
Inspection Gages effective for Weber or Ipeco seats as given  
on each gage.

1. Captain Seat Track Wear Inspection (Figs. 1, 2)

XXXXX      \_\_\_\_\_      A. Procedure

(1) To do a check on the surface of the seat track, do the  
steps that follow:

(a) Put the point of the applicable inspection gage in  
a groove that is on the surface of the seat track.

(b) If the protrusion touches the surface of the seat  
track, replace the seat track.

(2) To do a check of the lock hole, do the steps that  
follow:

(a) Put the protrusion of the applicable inspection gage  
in the lock hole.

(b) If the bottom of the inspection gage touches the  
surface of the seat track, replace the seat track.

2. First Officer Seat Track Wear Inspection (Figs. 1, 2)

XXXXX      \_\_\_\_\_      A. Procedure

(1) To do a check on the surface of the seat track, do the  
steps that follow:

(a) Put the point of the applicable inspection gage in  
a groove that is on the surface of the seat track.

---

REVISION DATE: 05/25/06

ATA AIRLINES, INC. B737-800 FLEET

W/C #: 321I2502

DATE WORK CARD COMPLETE \_\_\_/\_\_\_/\_\_\_

A/C NUMBER:

CHECK BEING PERFORMED: Cust

W/C NUMBER: 321I2502 (continued)

MECH: INSP:

---

(b) If the protrusion touches the surface of the seat track, replace the seat track.

(2) To do a check of the lock hole, do the steps that follow:

(a) Put the protrusion of the applicable inspection gage in the lock hole.

(b) If the bottom of the inspection gage touches the surface of the seat track, replace the seat track.

\*\*\*\*\* END OF WORKCARD \*\*\*\*\*

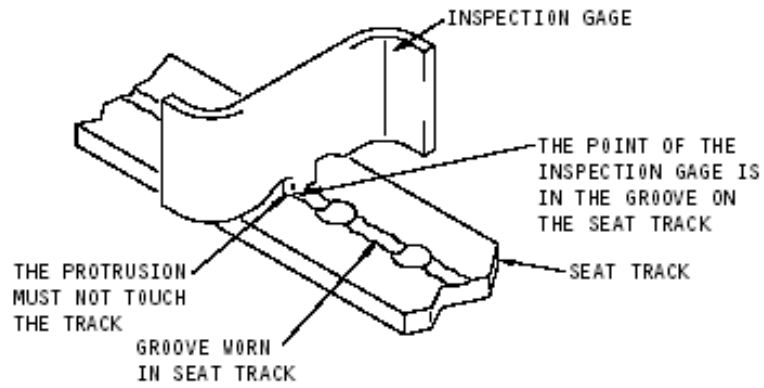

INSPECTION ON THE SURFACE OF THE SEAT TRACK

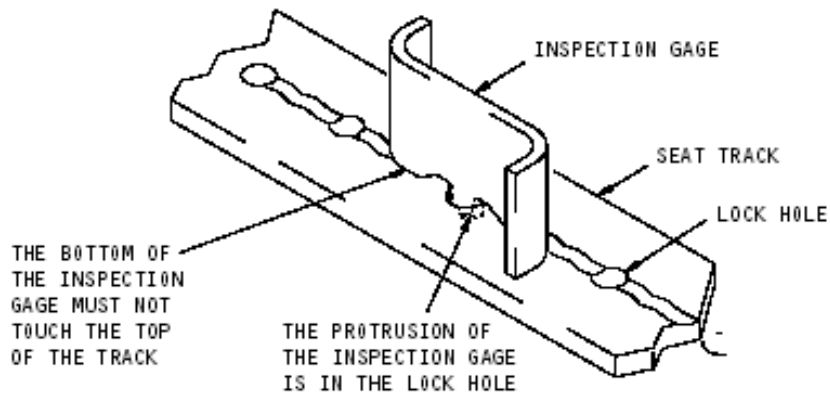

INSPECTION OF THE LOCK HOLE

Seat Track Inspection

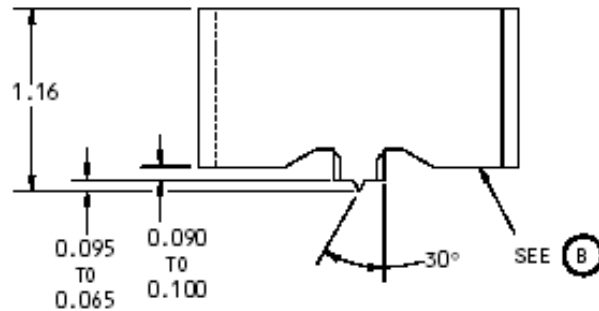
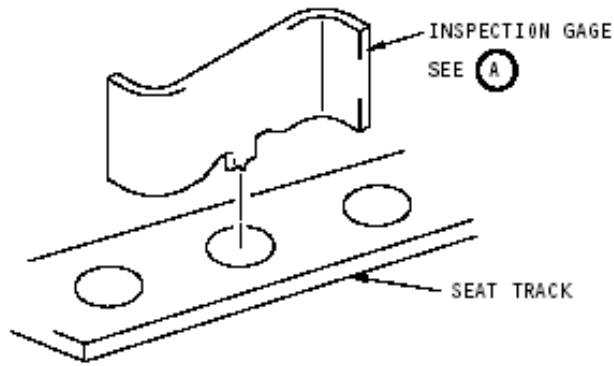

INSPECTION GAGE  
(SIDE VIEW)

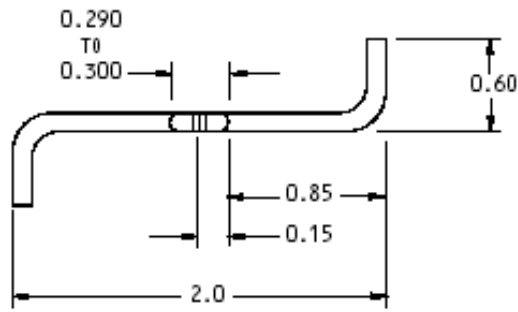

INSPECTION GAGE  
(BOTTOM VIEW)

(B)

NOTE: ALL DIMENSIONS ARE IN INCHES.

Seat Track Inspection Gage