

ZONES: 222
A/C NUMBER:
REV. DATE: 08/13/07
FREQUENCY:

W/C NUMBER: 322R2502 DATE:

PANELS

841

REFERENCES

Figure 1; W/C 382F2503

MECH INSP

MPD ITEM: 25-240-00

NOTE: Accomplish after W/C 382F2503, if issued.

_____ XXXXX 1. Fwd Galley Service Door Escape Slide Pack and Cover Removal
(Fig. 1).

NOTE: N/A this step if the pack and cover have been
previously removed from the door or operationally tested.

A. Make sure the door is safe as follows:

(1) Make sure the door is closed and latched.

WARNING: MAKE SURE THE GIRT BAR IS INSTALLED IN THE GIRT BAR
RETAINER. IF NOT, ACCIDENTAL INFLATION OF THE
ESCAPE SLIDE CAN OCCUR. THIS CAN CAUSE INJURIES TO
PERSONS OR DAMAGE TO EQUIPMENT.

(2) Make sure the girt bar [4] is installed in the girt bar
retainers [5].

B. Remove the escape slide pack and cover [2] from the door as
follows:

(1) Remove the screws [9] and washers [10] that attach the
cover [3] to the door.

(2) Pull the top of the cover [3] inboard until it is clear
of the door structure.

WARNING: THE ESCAPE SLIDE PACK AND COVER WEIGH APPROXIMATELY
55 POUNDS. BE CAREFUL WHEN YOU LIFT OR MOVE THE
ESCAPE SLIDE PACK AND COVER. IF YOU LIFT OR MOVE
THE ESCAPE SLIDE PACK AND COVER INCORRECTLY,
INJURIES TO PERSONS OR DAMAGE TO EQUIPMENT CAN
OCCUR.

(3) Lift and remove the escape slide pack and cover [2] to
disengage the lower fitting [15] from the bottom support
bracket [14].

A/C NUMBER:

CHECK BEING PERFORMED: Cust

W/C NUMBER: 322R2502 (continued)

MECH: INSP:

(4) Put the escape slide pack and cover [2] on a clean horizontal surface with the cover backing pan [11] against the horizontal surface.

_____ XXXXX 2. Remove the escape slide pack [26] from the cover [3] as follows (Fig. 1):

| NOTE: N/A this step and step 3. if slide pack and cover were
| removed to facilitate door maintenance/inspection or
| the pack has been operationally tested.

A. Remove the safety pin [19] from the pocket [18] on the escape slide pack [26].

WARNING: MAKE SURE YOU PUT THE SAFETY PIN INTO THE INFLATION CYLINDER VALVE. IF YOU DO NOT PUT THE SAFETY PIN INTO THE VALVE, THE ESCAPE SLIDE CAN ACCIDENTALLY INFLATE. THIS CAN CAUSE INJURIES TO PERSONS OR DAMAGE TO EQUIPMENT.

B. Put the safety pin [19] into the inflation cylinder valve [17] as shown.

C. Remove the girt bar [4] from the girt bar retainers [5].

D. Remove the latch [7] from the latch bracket [13].

E. Open the cover [3] to get access to the bonding jumpers [12].

NOTE: When the compartment is open, the escape slide pack can expand. Plan the work so the compartment is open for a minimum time to avoid the expansion of the escape slide pack.

F. Remove the pin [33], ladder tie [32], and stud [31] that attach the bonding jumpers [12] to the backing pan [11] as shown.

G. Fully open the cover [3] to get access to the escape slide pack [26].

H. Ensure the safety pin [19] is in the inflation cylinder valve [17] as shown.

A/C NUMBER:

CHECK BEING PERFORMED: Cust

W/C NUMBER: 322R2502 (continued)

MECH: INSP:

I. AIRPLANES WITH STRAP [PRE-SB 25-1378 OR PRE-PRR 38351];
Disconnect the escape slide strap [23] from the backing pan strap [25].

NOTE: The straps are behind the escape slide pack [26] and in the backing pan [11].

J. Remove the escape slide pack [26] from the backing pan [11] and put it on a clean horizontal surface.

NOTE: The slide must be installed in the transport box immediately after removal from the backing pan. If it takes too long, the slide will grow and not fit into the backing pan.

K. If required, remove the locknut [29] and screw [27] to remove the latch [7] from the girt release strap [28].

NOTE: The latch [7] may be needed for the replacement escape slide.

L. Record removed Escape Slide Assembly Serial Number.

(1) Serial Number removed: _____

_____ 3. (RII) Replace the escape slide pack [26] with serviceable unit in the cover [3] as follows (Fig. 1):

A. Record Serial Number of Escape Slide Assembly to be installed.

(1) Serial Number to be installed: _____

B. Make sure the cover [3] and backing pan [11] are on a clean horizontal surface with the backing pan [11] against the clean horizontal surface.

C. Make sure the cover [3] is open.

NOTE: When the compartment is open, the escape slide pack can expand. Plan the work so the compartment is open for a minimum time to avoid the expansion of the escape slide pack.

WARNING: IF THE SAFETY PIN IS NOT IN THE INFLATION CYLINDER VALVE, THE ESCAPE SLIDE CAN ACCIDENTALLY INFLATE.

A/C NUMBER:

CHECK BEING PERFORMED: Cust

W/C NUMBER: 322R2502 (continued)

MECH: INSP:

ACCIDENTAL INFLATION OF THE ESCAPE SLIDE CAN CAUSE INJURIES TO PERSONS AND DAMAGE TO EQUIPMENT.

D. Make sure the safety pin [19] is in the inflation cylinder valve [17].

E. Put the escape slide pack [26] in the backing pan [11].

NOTE: The slide must be installed in the backing pan immediately after removal from the transport box. If it takes too long, the slide will grow and not fit into the backing pan.

NOTE: If the escape slide pack expands and can not be fitted into the compartment, a new escape slide pack must be installed.

F. AIRPLANES WITH STRAP [PRE-SB 25-1378 OR PRE-PRR 38351]; Connect the escape slide strap [23] and the backing pan strap [25] under the escape slide pack [26].

G. Make a "Z" fold [21] in the girt [6] as shown.

H. Align and push together the velcro strips [24] on the bottom side of the girt [6] with the velcro strips [24] on the backing pan shelf [22].

NOTE: The velcro strips should be clean and function as intended.

I. Align and push together the velcro strip [24] on the girt retainer flap [20] and the velcro strip [24] on the girt [6].

J. If required, install the screw [27] and locknut [29] to attach the latch [7] to the girt release strap [28].

K. Make sure there is no tension in the firing cable [30]. If there is tension in the firing cable [30], do not remove the safety pin [19].

(1) Make sure the slide is correctly installed in the backing pan [11].

(2) Make sure the "Z" fold in the girt is correct.

A/C NUMBER:

CHECK BEING PERFORMED: Cust

W/C NUMBER: 322R2502 (continued)

MECH: INSP:

WARNING: BE CAREFUL WHEN YOU HANDLE THE ESCAPE SLIDE PACK. WHEN THE SAFETY PIN IS REMOVED FROM THE INFLATION CYLINDER VALVE, THE ESCAPE SLIDE CAN ACCIDENTALLY INFLATE. THIS CAN CAUSE INJURIES TO PERSONS OR DAMAGE TO EQUIPMENT.

L. Remove the safety pin [19] from the inflation cylinder valve [17].

M. Put the safety pin [19] into the pocket [18] on the escape slide pack [26].

N. Close the cover [3] sufficiently to connect the bonding jumpers [12] to the backing pan [11].

O. Install the stud [31], ladder tie [32] and pin [33] to attach the bonding jumpers [12] to the backing pan [11].

P. Close the cover [3].

Q. Make sure you can clearly see the inflation cylinder pressure gage [16] in the the window [1]. If necessary, adjust as follows:

(1) Move the escape slide pack [26] to get the pressure gage [16] in the center of the window [1].

R. Make sure the distance between the center of the lower edge of the cover [3] to the center of the girt bar [4] is 10.5-12.0 inches.

S. Align the holes in the latch bracket [13] and latch bracket [35] to install the latch [7].

T. Install the latch [7] in the latch bracket [13] and latch bracket [35] as shown.

U. Make sure that the sum of the clearances at 'A' and 'B' between the latch brackets [13] and [35] is no more than 0.01 inch (Fig. 1).

V. Install the girt bar [4] into the floor-mounted brackets [8] to make sure you can arm the escape slide.

W. Install the girt bar [4] in the girt bar retainers [5].

_____ 4. (RII) Escape Slide Pack and Cover Installation (Fig. 1).

A/C NUMBER:

CHECK BEING PERFORMED: Cust

W/C NUMBER: 322R2502 (continued)

MECH: INSP:

A. Make sure the door is closed and latched.

WARNING: THE ESCAPE SLIDE WILL NOT OPERATE IF THE SAFETY PIN IS IN THE INFLATION CYLINDER VALVE. IF THE ESCAPE SLIDE DOES NOT OPERATE, PERSONS MAY BE INJURED.

B. Ensure the safety pin [19] is not installed in the inflation cylinder valve [17].

WARNING: BE CAREFUL WHEN YOU LIFT THE ESCAPE SLIDE PACK AND COVER. THE ESCAPE SLIDE WEIGHS APPROXIMATELY 55 POUNDS. IF YOU ARE NOT CAREFUL, INJURIES TO PERSONS AND DAMAGE TO EQUIPMENT CAN OCCUR.

C. Install the escape slide pack and cover [2] on the door so the lower fitting [15] engages the bottom support bracket [14].

D. Push the top of the escape slide pack and cover [2] outboard until it is against the door.

E. Install the screws [9] and washers [10] that attach the cover [3] to the door.

F. Make sure you can arm the escape slide by installing the girt bar [4] into the floor-mounted brackets [8].

G. Install the girt bar [4] into the girt bar retainer [5].

***** END OF WORKCARD *****

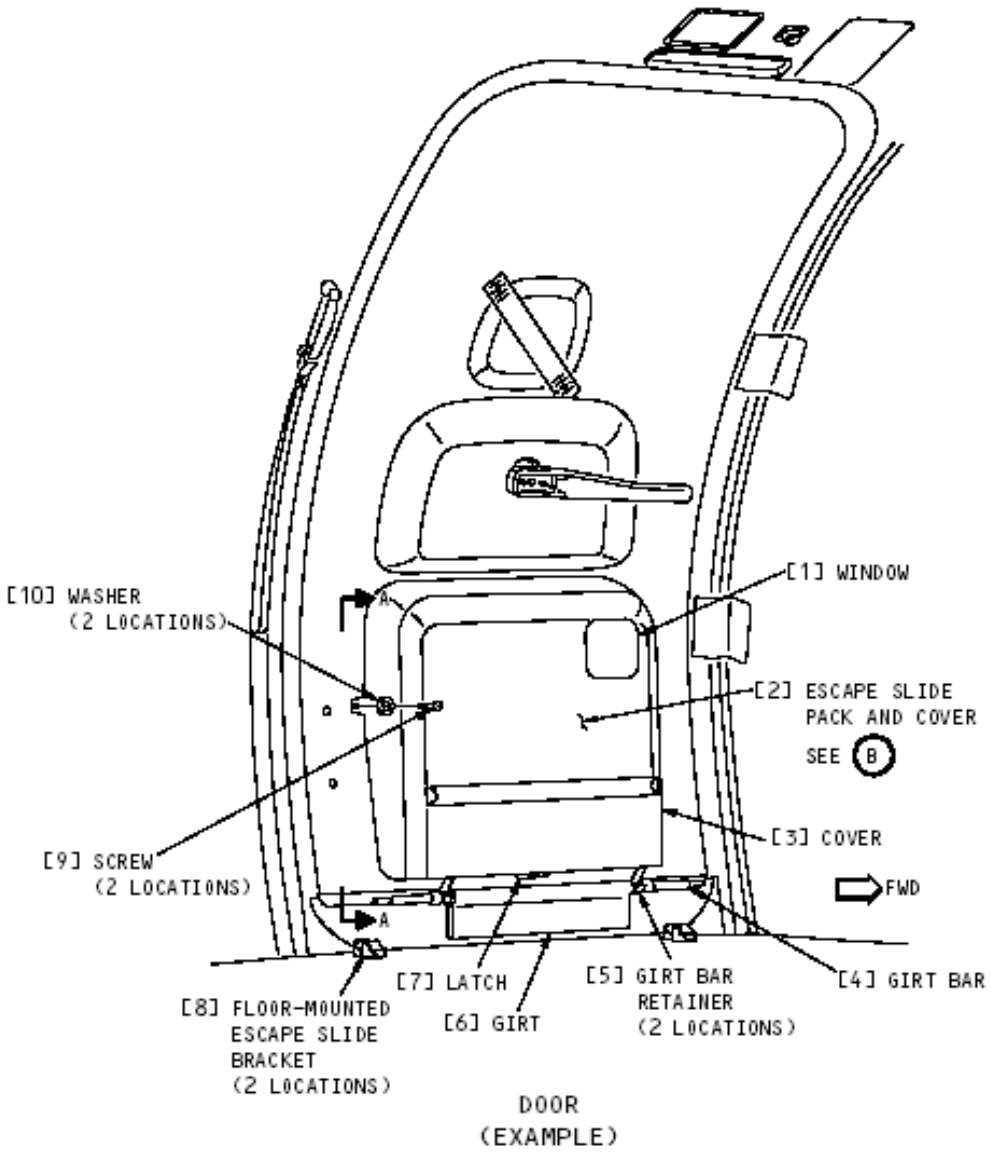

Escape System Installation

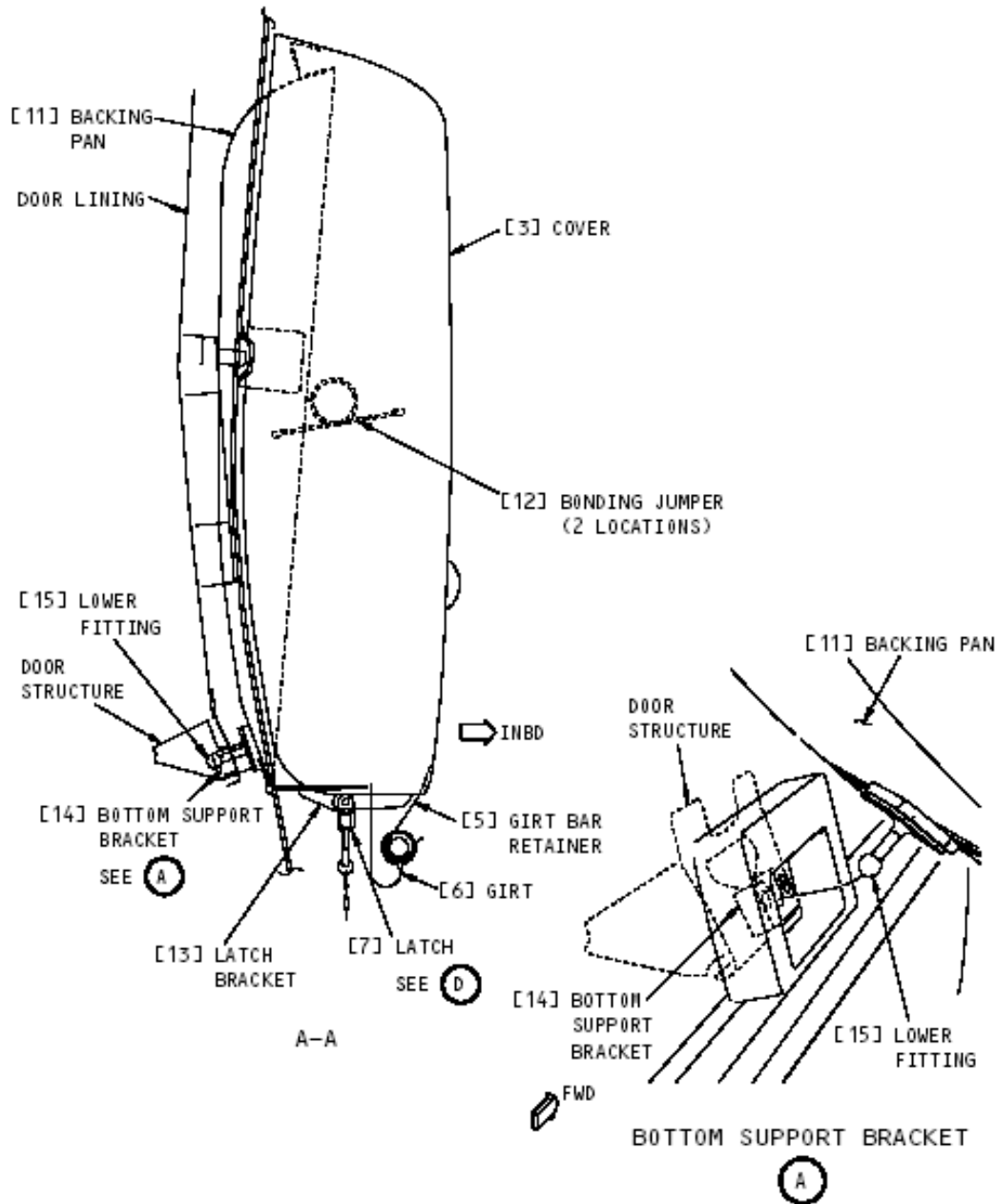

Escape System Installation

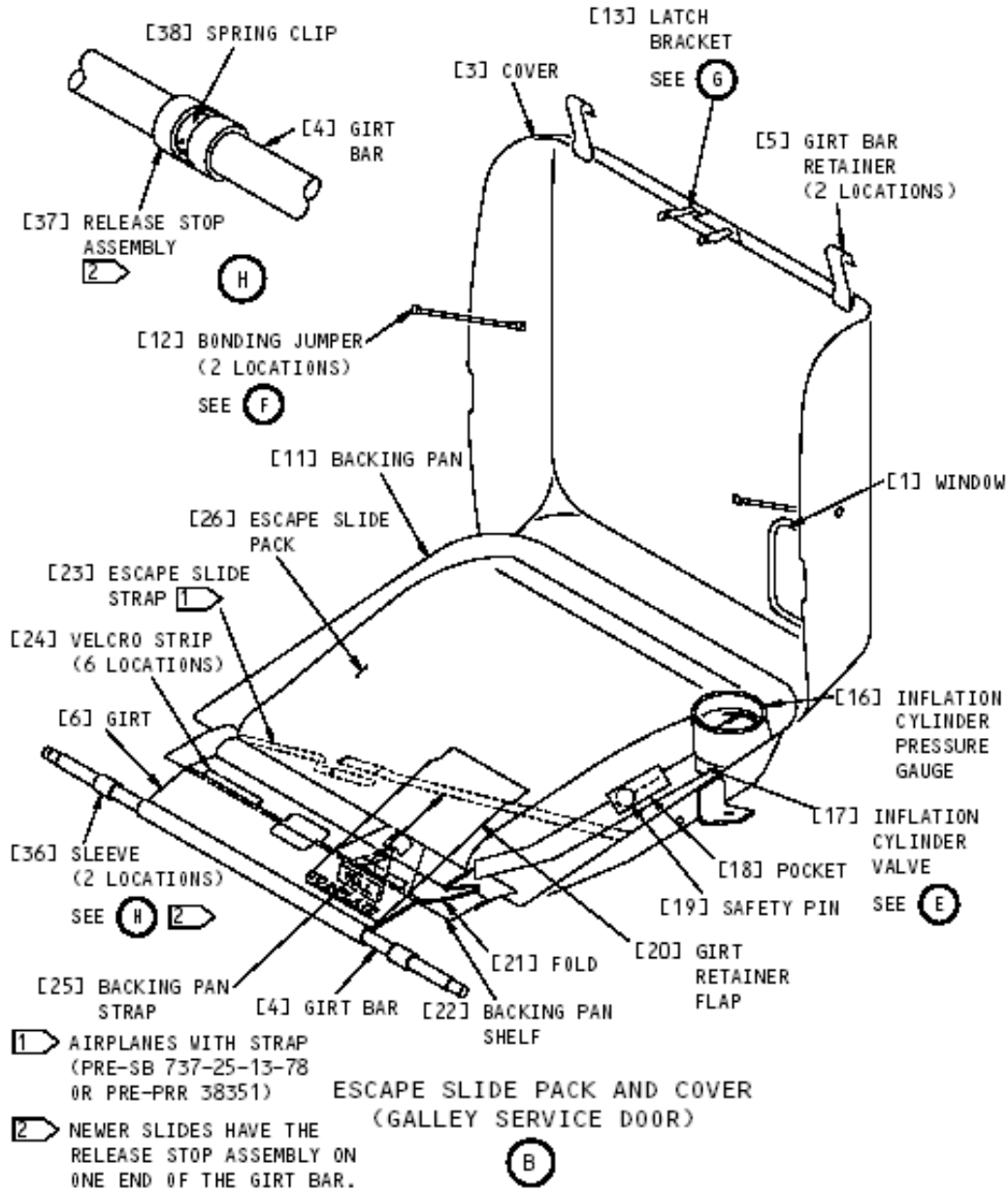

Escape System Installation

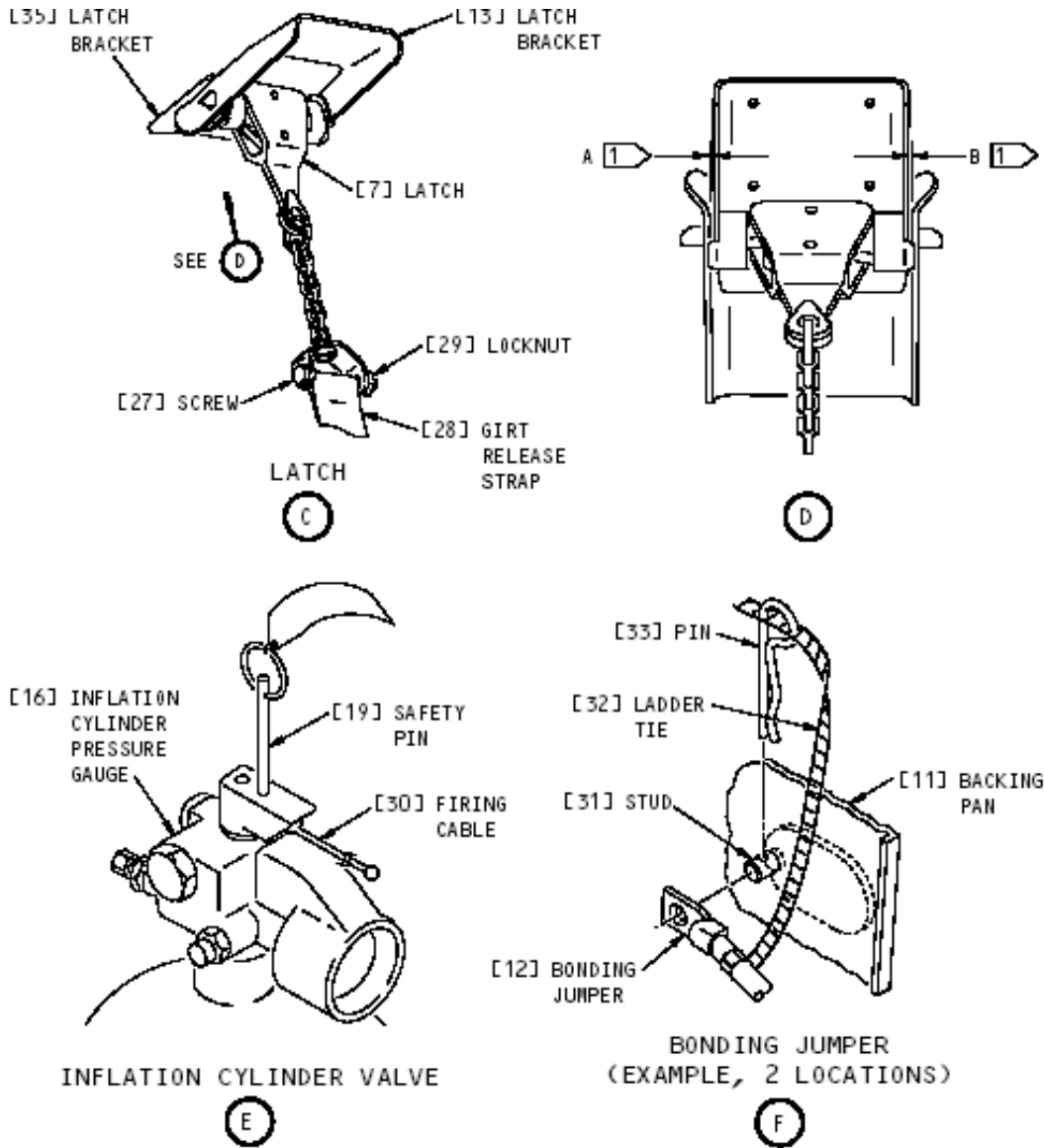

1 THE SUM OF THE CLEARANCES AT A AND B MUST BE NO MORE THAN 0.01 INCH (0.254 mm)

Escape System Installation

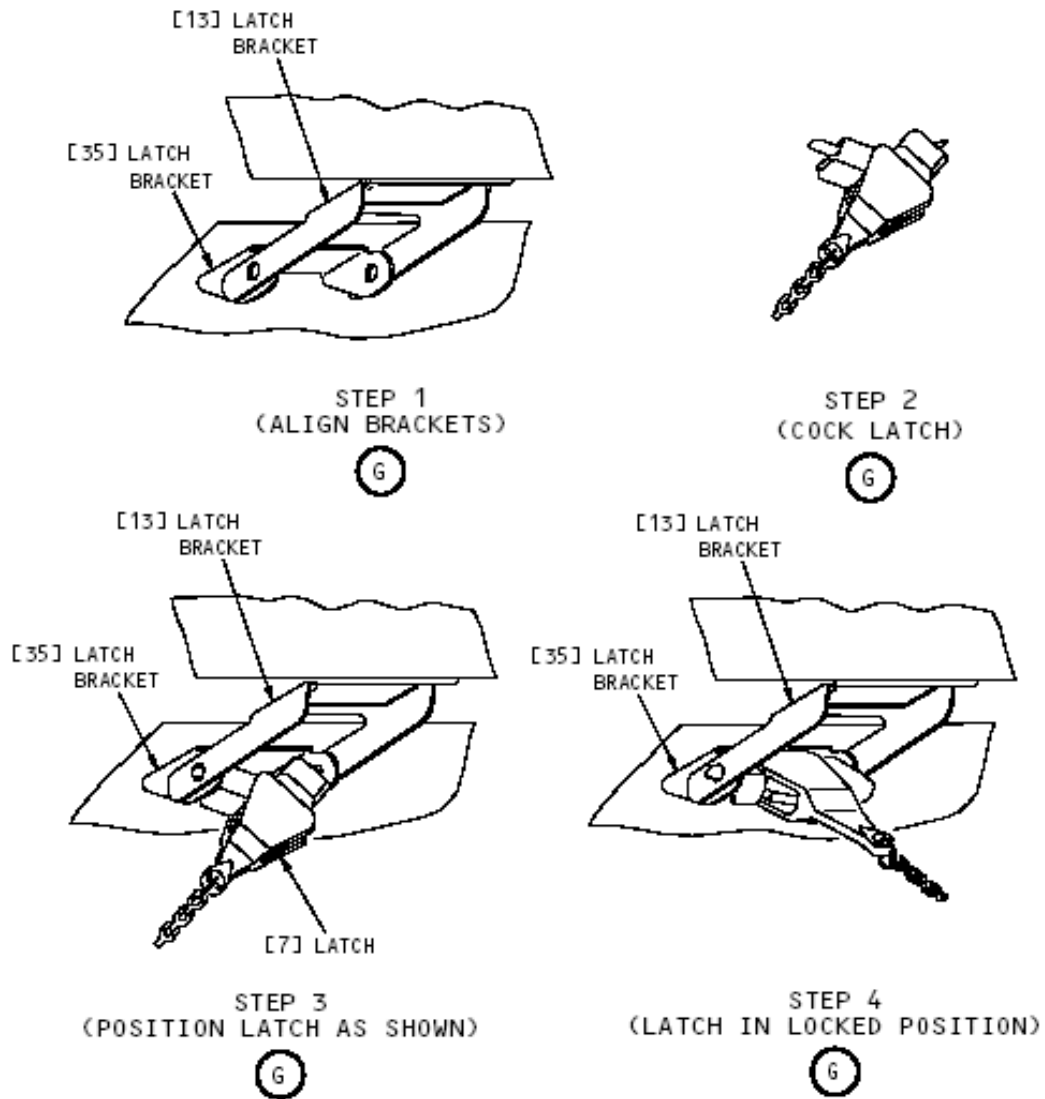

Escape System Installation