



- (3) Remove the packing [6] from the filter [7].
- (4) Remove the packing [10], and the backup rings [5] from the filter head.
- (5) Examine the filter [7] for metal contamination.
- (6) Examine the filter bowl for metal contamination.
- (7) If the filter [7] or filter bowl [8] contains metal contamination, do these tasks: Hydraulic Systems A and B Engine-Driven Pump (EDP) Removal  
(AMM TASK 29-11-11-000-802 p401)  
Hydraulic System A or B Flushing  
(AMM TASK 29-11-00-170-801 p201)  
Hydraulic Systems A and B Engine-Driven Pump (EDP) Installation (AMM TASK 29-11-11-400-802 p401)
- (8) Clean the filter bowl [8].

2. EDP Case Drain Filter Element Installation  
(Figures 1 and 2).

\_\_\_\_\_ XXXXX A. Procedure

- (1) Apply fluid, BMS3-11, TYPE IV to the backup rings [5], and new packing [10].
- (2) Install the backup rings [5] and the new packing [10] in the filter head groove.
- (3) Apply fluid, BMS3-11, TYPE IV to the new packing [6].
- (4) Install the new packing [6] in the filter element groove.
- (5) Install the filter [7] in the filter bowl [8].
- (6) Apply fluid, BMS3-11, TYPE IV to the threads of the filter bowl [8].
- (7) Install the filter bowl [8] into the filter head.

(a) Tighten the filter bowl [8] to 96-120 pound-inches (10.8-13.6 newton-meters).

(b) Install lockwire. To install it, do this task:  
Lockwires Installation  
(AMM TASK 20-10-44-400-801 p401).

| \_\_\_\_\_ XXXXX B. EDP Case Drain Filter Element Installation Test

| (1) Pressurize the applicable hydraulic reservoir. To pressurize it, do this task: Hydraulic Reservoirs Pressurization (AMM TASK 29-11-01-860-801 p201).

| (2) Pressurize the applicable hydraulic system with the engine driven pump. To pressurize the system, do this task: Dry Motor the Engine:  
(AMM TASK 71-00-00-700-821-F00 p201).

(3) Make sure the hydraulic pressure becomes stable between 2800 and 3200 psi.

(4) Make sure the case drain filter assembly does not have a leak.

(5) Close the #1 engine fan cowls, Do this task:  
Close the Fan Cowl Panels  
(AMM TASK 71-11-02-010-801-F00 p201).

(6) Remove the hydraulic power from the A hydraulic system. To remove it, do this task: Hydraulic System A or B Power Removal  
(AMM TASK 29-11-00-860-805 p201).

(7) If it is necessary, do this task: Hydraulic Reservoir Servicing (AMM TASK 12-12-00-610-801 p301).  
\*\*\*\*\* END OF WORKCARD \*\*\*\*\*

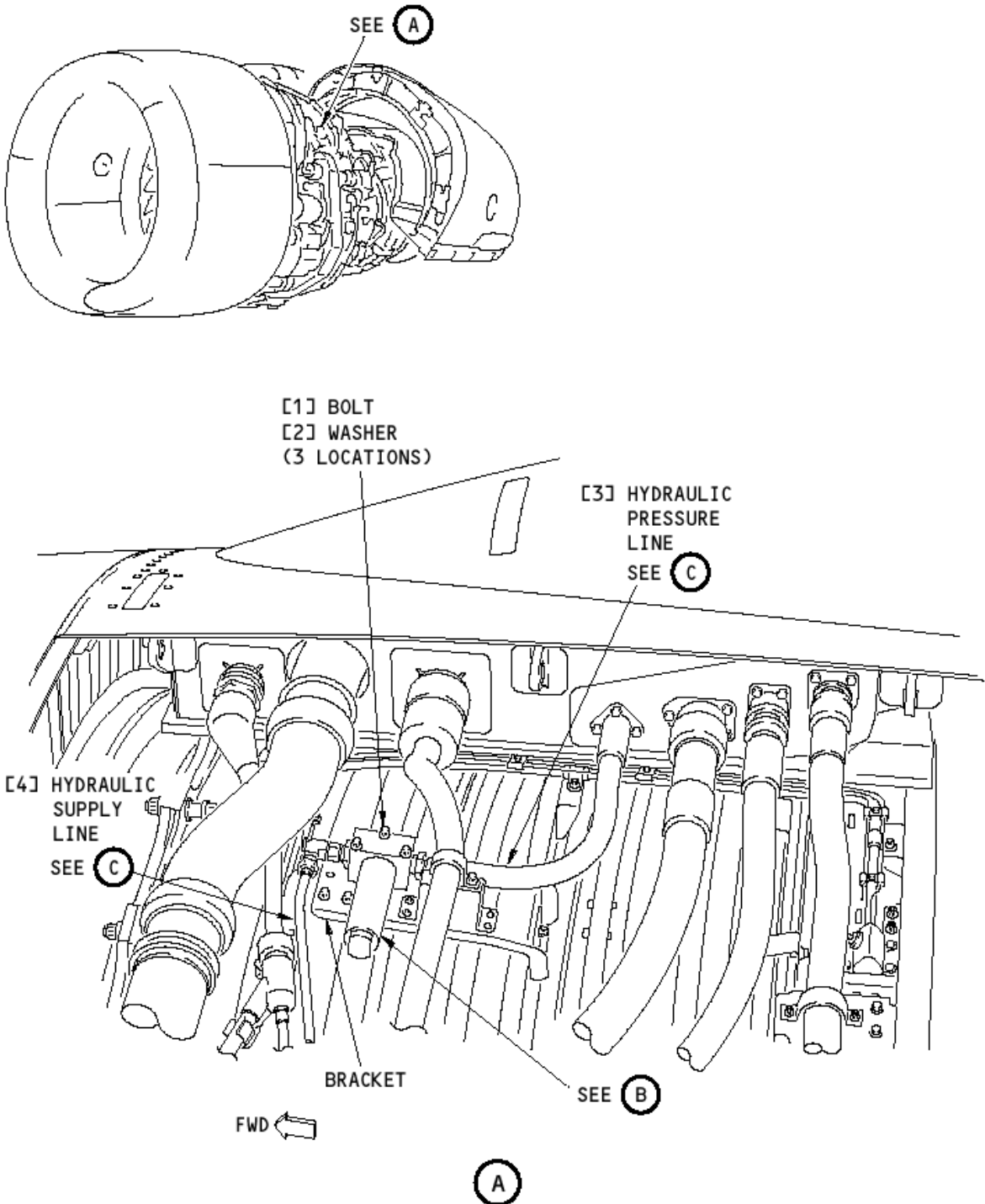

EDP Case Drain Filter

FIGURE 1

