

ATA AIRLINES, INC.

FORWARD PASSENGER DOOR, DOOR STOPS, LATCHES, AND HINGES

PAGE 1 / 1

CHECK BEING PERFORMED: Custom

ZONES: 200 800

W/C NUMBER: 382I5201

DATE:

A/C NUMBER:

REV. DATE: 12/21/04

FREQUENCY: 2A

PANELS

831

REFERENCES

FIGURES 1 THROUGH 3

MECH INSP

EXTERNAL - ZONAL (GV): FORWARD PASSENGER DOOR INCLUDING DOOR STOPS, LATCHES, AND HINGES

NOTE: If workcard is being worked in a Line Maintenance environment, work with B737 Line Service Check "External Zonal Inspection, Passenger Entry Doors" task.

XXXXX 1. Perform an External Zonal Inspection (GV) of the Forward Passenger Door - Section 41, STA 345 (Figures 1 and 2).

XXXXX 2. Perform an External Zonal Inspection (GV) of the Forward Passenger Entry Door Stops, Latches, and Hinges - Section 41, STA 345 (Figure 3).

XXXXX 3. Ensure placard "The Employees of ATA Welcome You Aboard" is installed at the L1 entry door, per E/O FLT-11PL-2405.

*****END OF WORKCARD*****

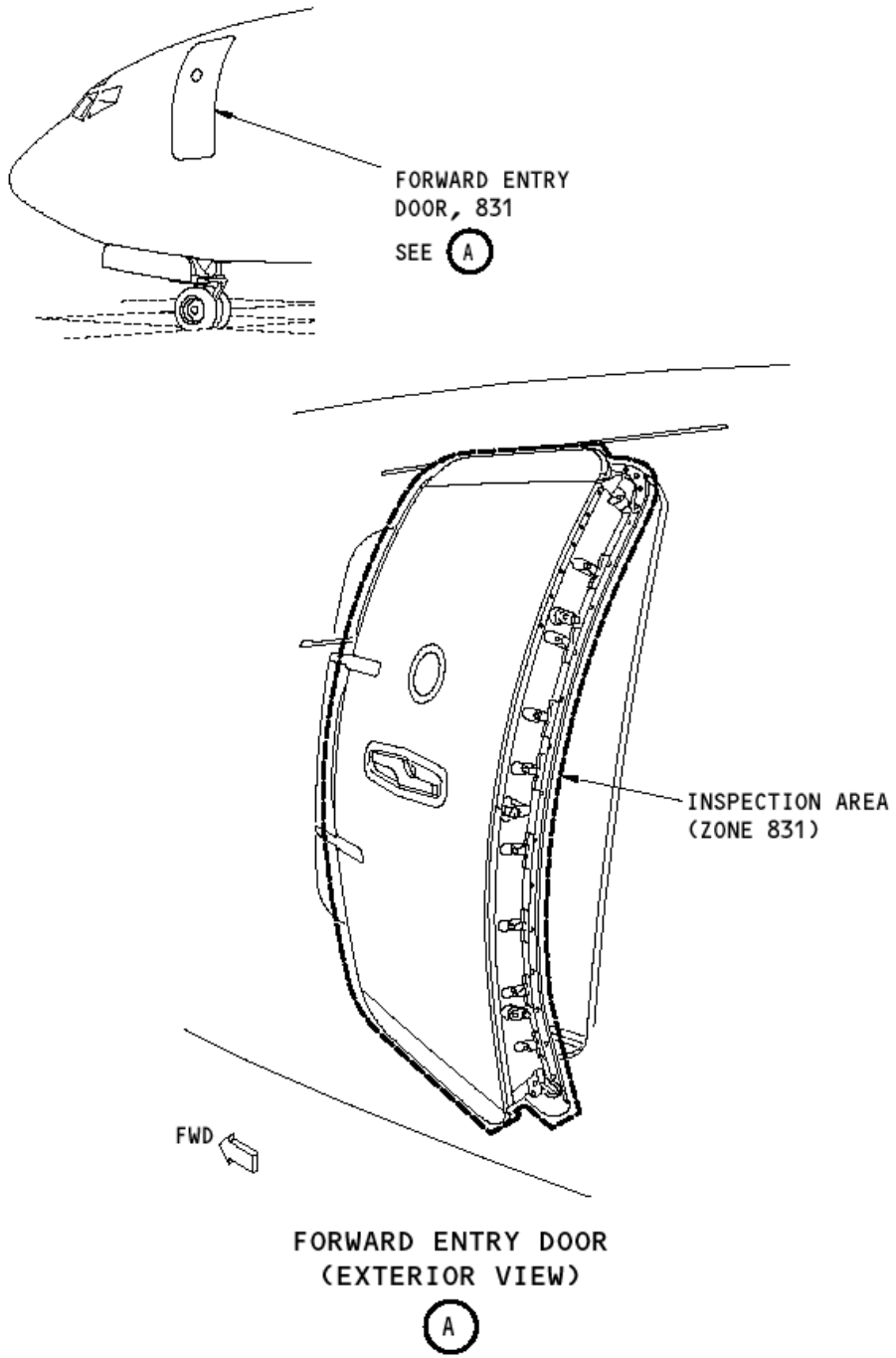

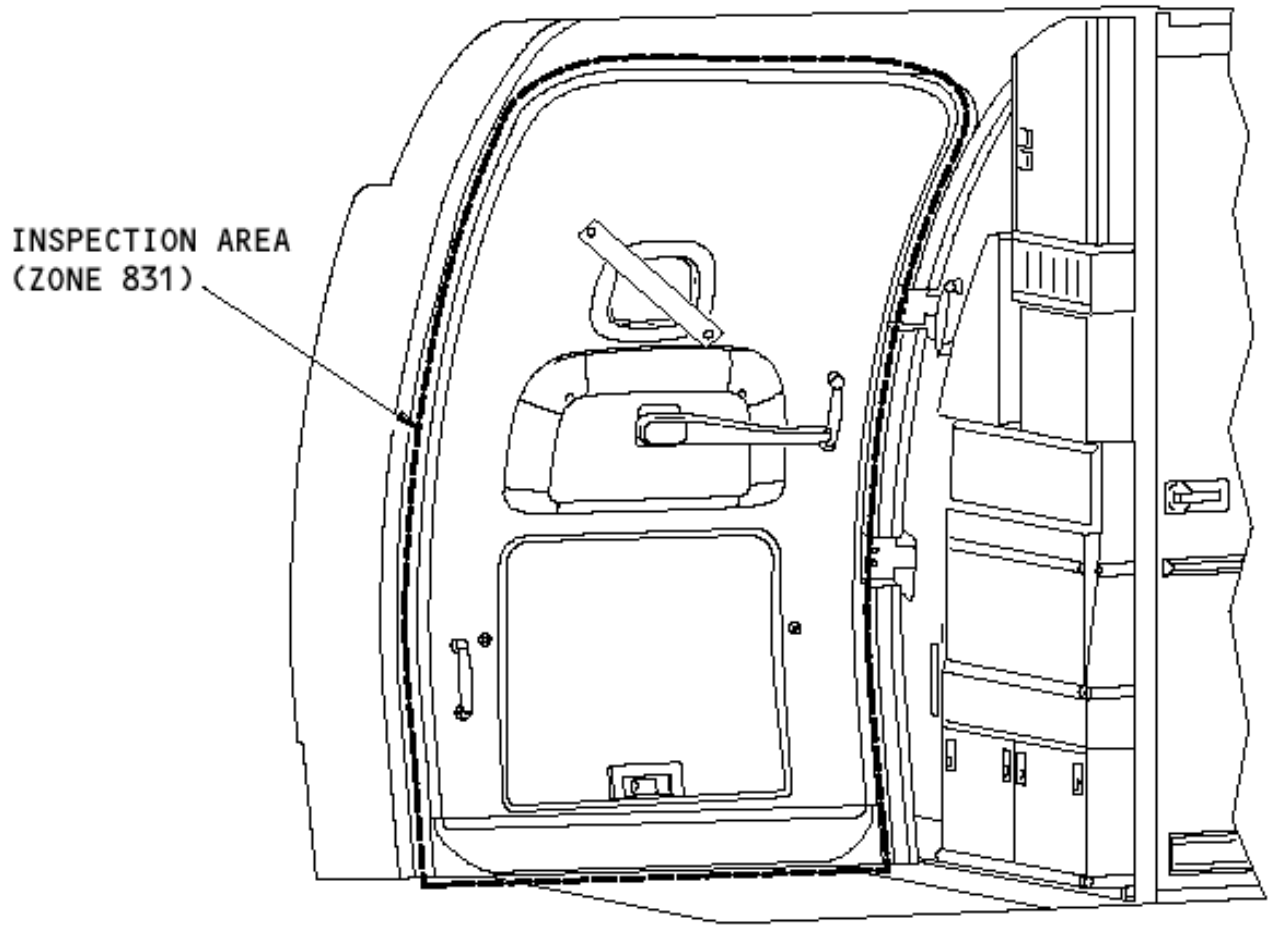

➔ FWD

FORWARD ENTRY DOOR
(INTERIOR VIEW)

A

