

ATA AIRLINES, INC.

FORWARD GALLEY SERVICE DOOR, DOOR STOPS, LATCHES, AND HINGES

PAGE 1 / 1

CHECK BEING PERFORMED: Custom

ZONES: 200 800

W/C NUMBER: 382I5202 DATE:

A/C NUMBER:

REV. DATE: 12/21/04

FREQUENCY: 2A

PANELS

841

REFERENCES

FIGURES 1 THROUGH 3

MECH INSP

EXTERNAL - ZONAL (GV): FORWARD GALLEY SERVICE DOOR INCLUDING DOOR STOPS, LATCHES, AND HINGES

| NOTE: If workcard is being worked in a Line Maintenance
| environment, work with B737 Line Service Check
| "External Zonal Inspection, Service Doors" task.

_____ XXXXX 1. Perform an External Zonal Inspection (GV) of the Forward Galley Service Door - Section 41, STA 340 (Figures 1 and 2).

_____ XXXXX 2. Perform an External Zonal Inspection (GV) of the Forward Galley Service Door Stops, Latches, and Hinges - Section 41, STA 340 (Figure 3).

*****END OF WORKCARD*****

REVISION DATE: 12/21/04

ATA AIRLINES, INC. B737-800 FLEET

W/C #: 382I5202

DATE WORK CARD COMPLETE ___/___/___

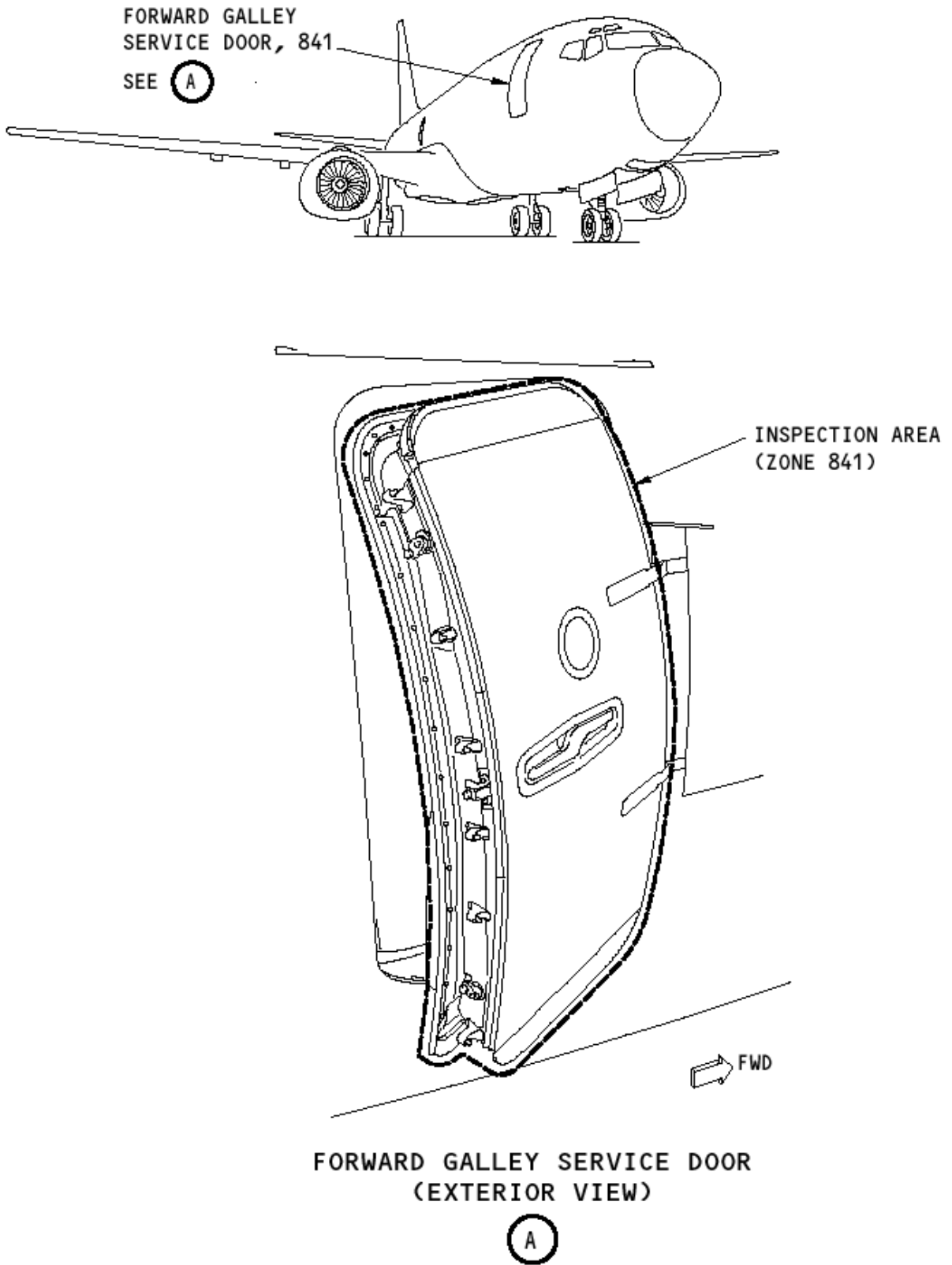

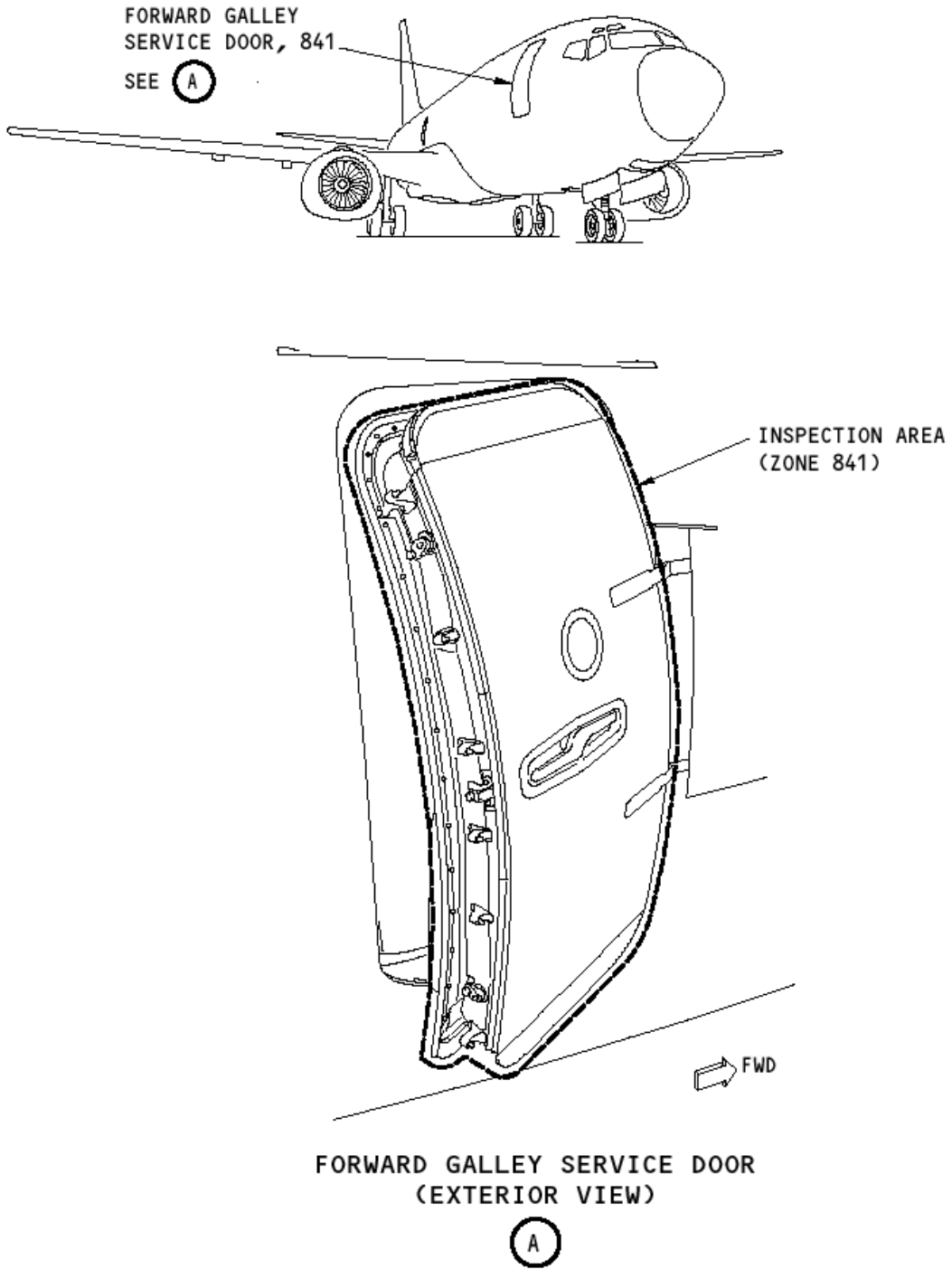

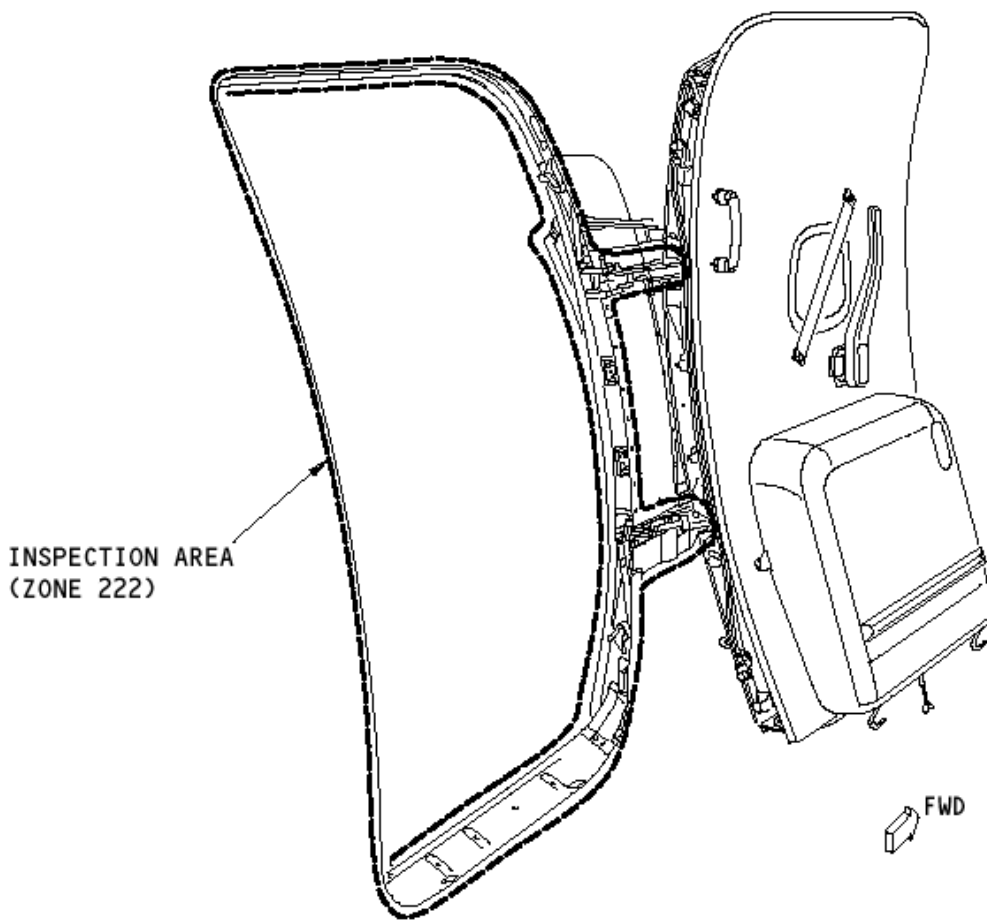
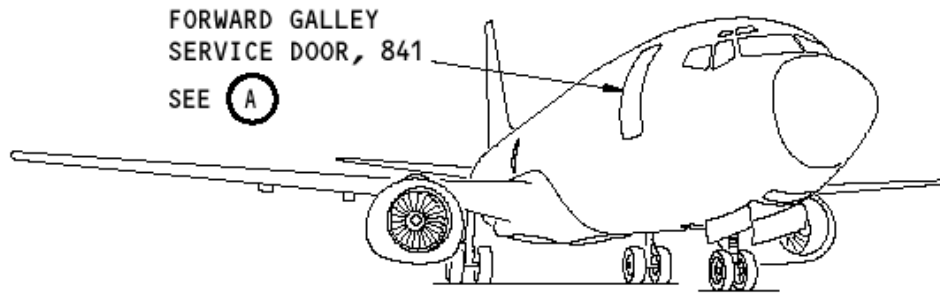

FORWARD GALLEY SERVICE DOOR

(A)