

ATA AIRLINES, INC.

AFT GALLEY SERVICE DOOR, DOOR STOPS, LATCHES, AND HINGES

PAGE 1 / 1

CHECK BEING PERFORMED: Custom

ZONES: 200 800
A/C NUMBER:
REV. DATE: 12/21/04
FREQUENCY: 2A

W/C NUMBER: 382I5204 DATE:

PANELS

844

REFERENCES

FIGURES 1 THROUGH 3

MECH INSP

EXTERNAL - ZONAL (GV): AFT GALLEY SERVICE DOOR INCLUDING DOOR STOPS, LATCHES, AND HINGES

| NOTE: If workcard is being worked in a Line Maintenance
| environment, work with B737 Line Service Check
| "External Zonal Inspection, Service Doors" task.

_____ XXXXX 1. Perform an External Zonal Inspection (GV) of the Aft Galley Service Door - Section 47, STA 980 (Figures 1 and 2).

_____ XXXXX 2. Perform an External Zonal Inspection (GV) of the Aft Galley Service Door Stops, Latches, and Hinges - Section 47, STA 980 (Figure 3).

*****END OF WORKCARD*****

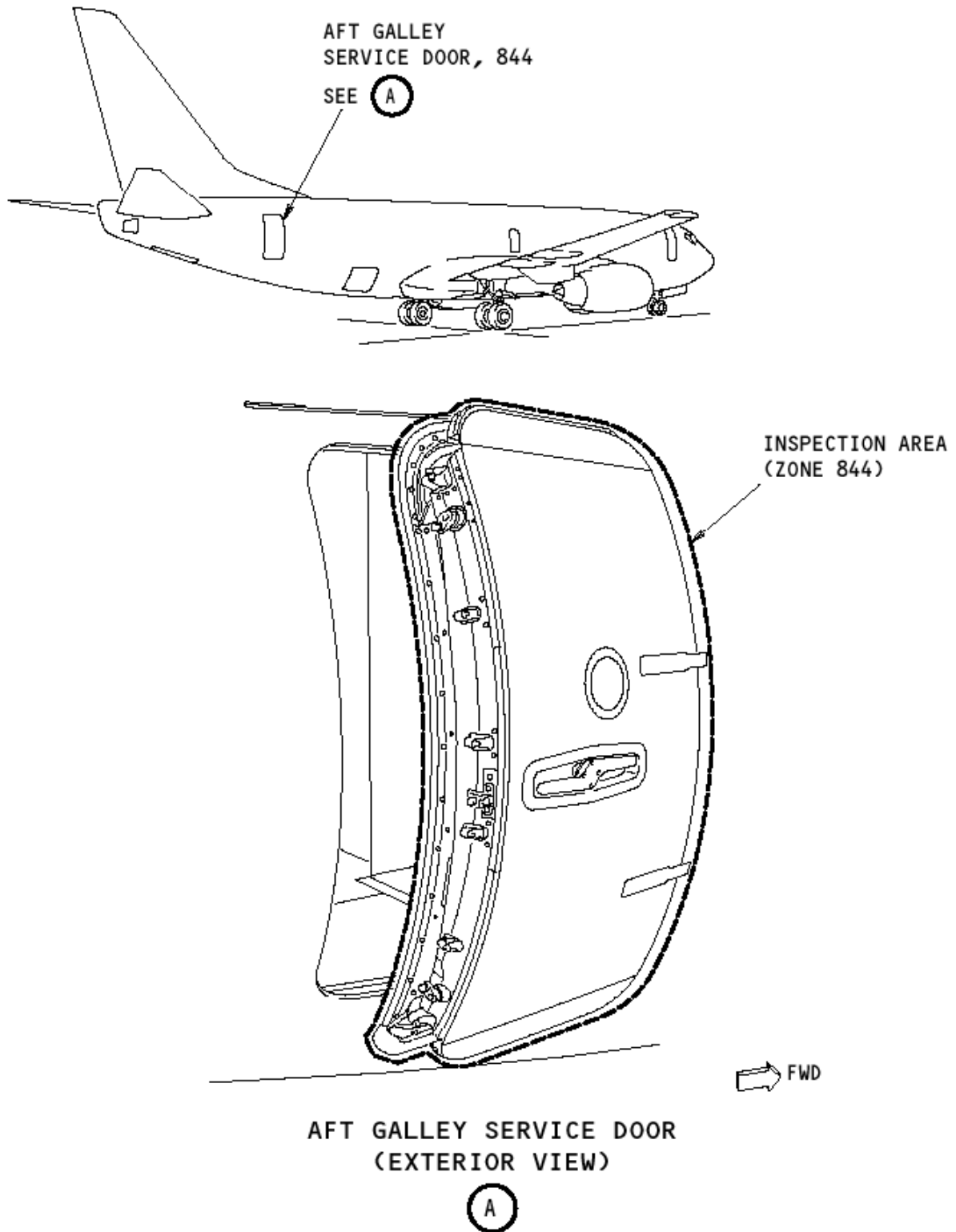

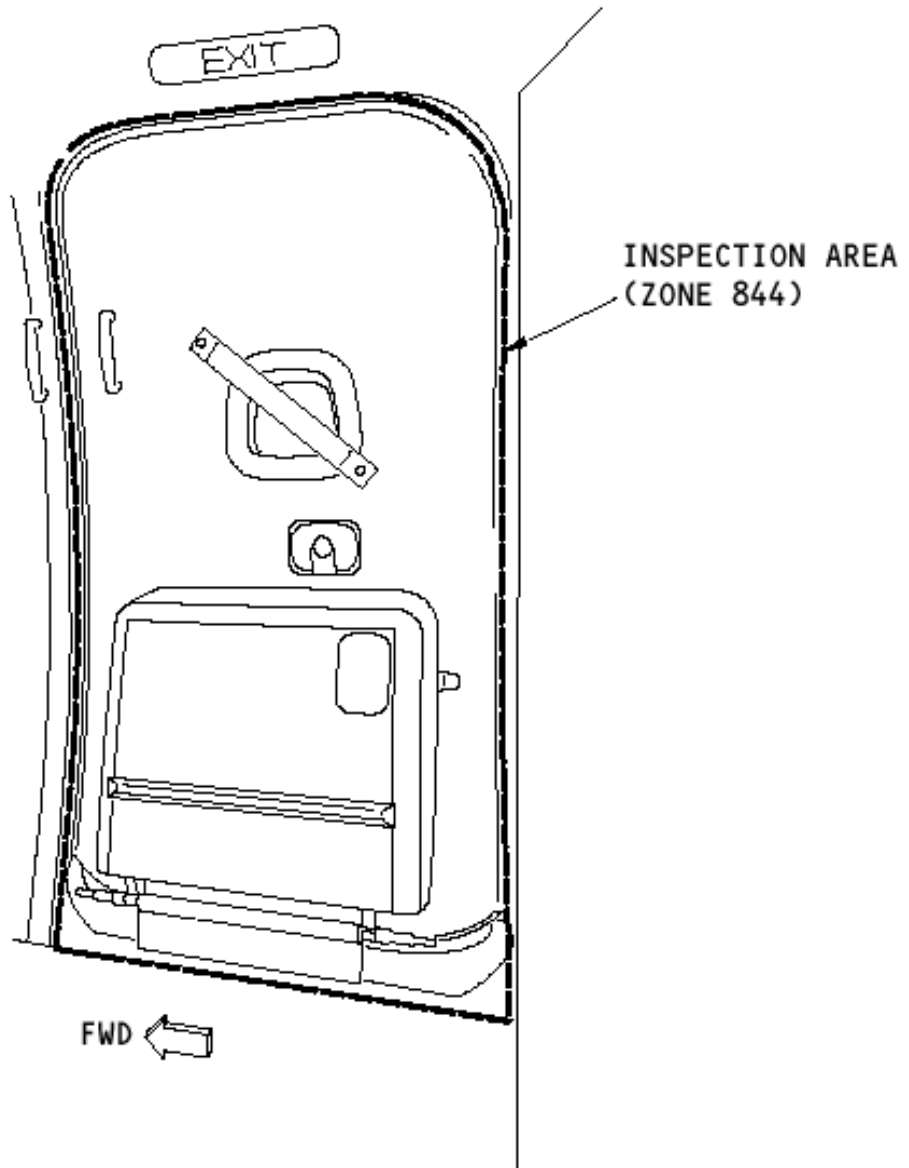

AFT GALLEY SERVICE DOOR
(INTERIOR VIEW)

A

