

CHECK BEING PERFORMED: Custom

ZONES: 200
A/C NUMBER:
REV. DATE: 03/23/00
FREQUENCY: 2C

W/C NUMBER: 521M3501
DATE:
W/O:
JAC CODE:



PANELS

NONE

REFERENCES

FIGURE 1 AND 2, MM 35-21-00 521M3501

MECH INSP

* NOTE: ACCOMPLISH AFTER CARD 522F3502 IS COMPLETED *

_____ XXXXX 1 INSTALL OXYGEN MASK DOOR RESTRAINTS.

_____ XXXXX 2 PERFORM DOOR DROP CHECK OF ALL PASSENGER OXYGEN MASKS PER MM
35-21-00 PB 501 STEP 4B ITEM 1 THROUGH 8.

| _____ XXXXX 3 PRIOR TO STOWING OXYGEN MASK DOORS, CHECK OXYGEN MASKS FOR
| CONDITION AND PROPER INSTALLATION (REF. FIGURE 1 AND 2).

| NOTE: LOWERING OF THE PSM IS NOT REQUIRED.

| _____ XXXXX 4 CLOSE ALL PSU DOORS AND REMOVE ALL OXYGEN MASK DOOR RESTRAINTS
| PER MM 35-21-00 PB 501 STEP 4B ITEM 9.

*****END OF WORKCARD*****

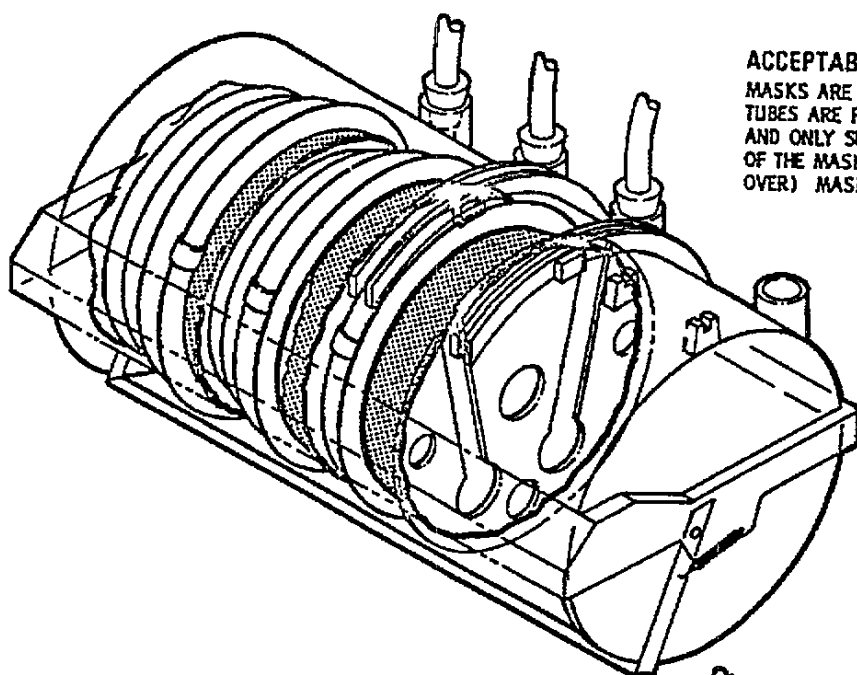

ACCEPTABLE MODULE
MASKS ARE EVENLY SPACED
TUBES ARE FIRMLY WRAPPED
AND ONLY SLIGHT DEFORMITIES
OF THE MASKS (EDGE NOT FOLDED
OVER) MASKS ALIGNED (NOT CANTED)

NOT ACCEPTABLE
MASKS ARE NOT EVENLY SPACED,
TUBES ARE LOOSE AND OVERLAP
ONE ANOTHER.

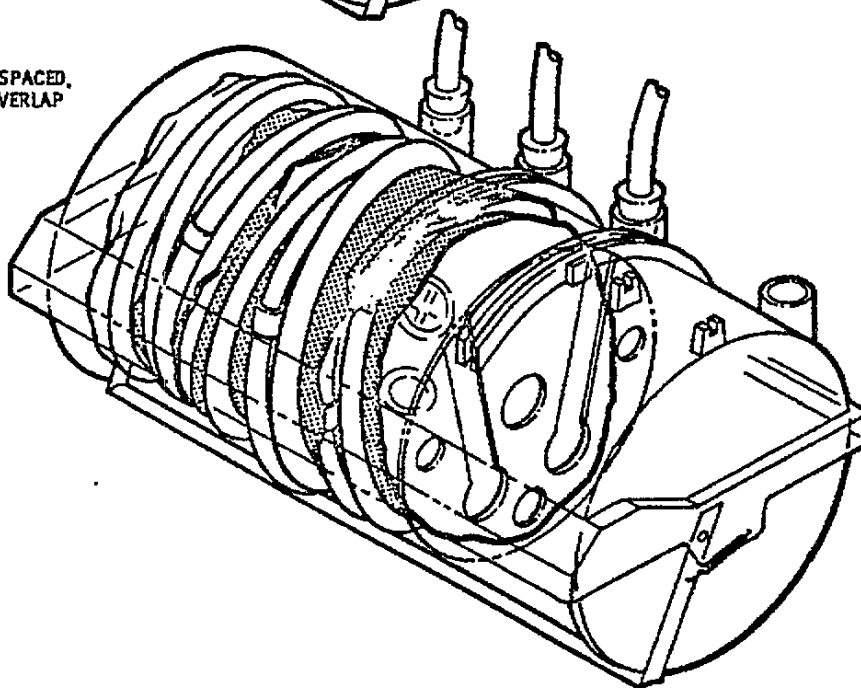

Oxygen Mask Installation - Outboard PSM

FIGURE 1

REVISION DATE 03/24/2000

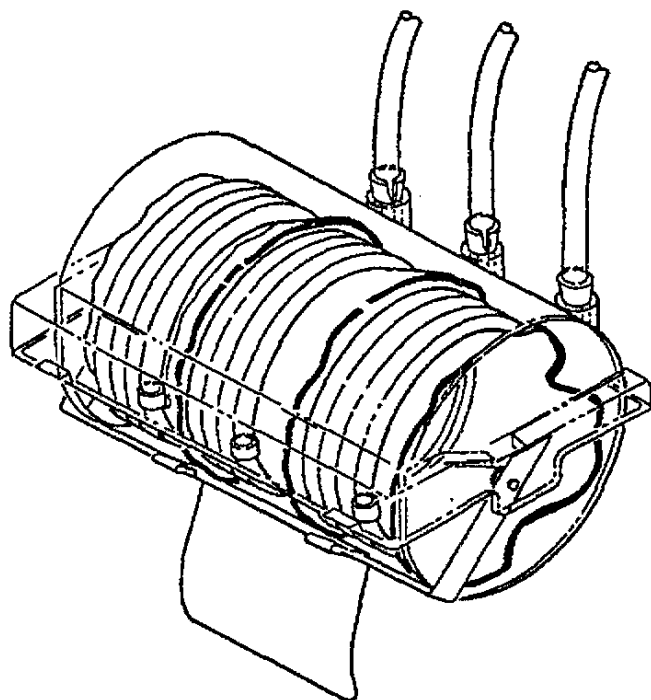

ACCEPTABLE MODULE
MASKS ARE EVENLY SPACED
TUBES ARE FIRMLY WRAPPED
AND ONLY SLIGHT DEFORMITIES
OF THE MASKS (EDGE NOT FOLDED
OVER) MASKS ALIGNED (NOT CANTED)

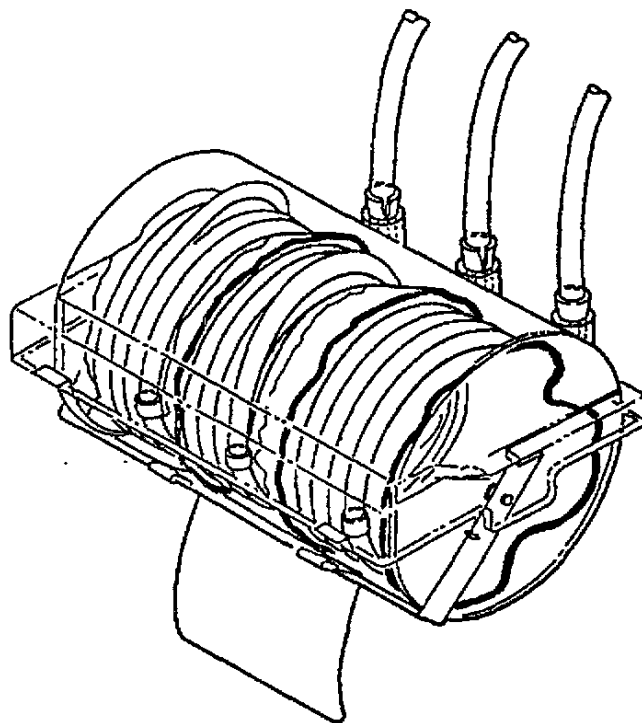

NOT ACCEPTABLE
MASKS ARE NOT EVENLY SPACED.
TUBES ARE LOOSE AND OVERLAP
ONE ANOTHER

Oxygen Mask Installation - Center PSM

FIGURE 2

REVISION DATE 03/24/2000