

CHECK BEING PERFORMED: Custom

ZONES: 410
 A/C NUMBER:
 REV. DATE: 04/07/06
 FREQUENCY: H2

W/C NUMBER: 541F7301 DATE:
 W/O:
 JAC CODE:



TOOLS	DESCRIPTION	QTY
UT1000/2	TEST SET (OR EQUIVALENT)	1
UT1179	LEAD (OR EQUIVALENT FOR CORRESPONDING TEST SET)	1
UT937/1	LEAD (OR EQUIVALENT FOR CORRESPONDING TEST SET)	1
UT997	LEAD (OR EQUIVALENT FOR CORRESPONDING TEST SET)	1
UT1124/1	LEAD (OR EQUIVALENT FOR CORRESPONDING TEST SET)	1

PANELS

NONE

REFERENCES

AMM 71-00-00 FIGURE 1 541F7301

MECH INSP

 PERFORM IN CONJUNCTION WITH WORKCARD 510F2150 IF ISSUED

NOTE: NOT APPLICABLE TO -22B ENGINES.

NOTE: ACCURACY IS ESSENTIAL IN PERFORMING CHECKS. DO NOT SHORT-CUT PROCEDURE.

NOTE: ISOLATE AIR AND ELECTRICAL LOADS, ENSURE THIS IS NOT BEING SHARED BY ANOTHER ENGINE.

NOTE: UTILIZE ONE PERSON TO MOVE AND CALL OUT THRUST LEVER MOVEMENT AND ANOTHER TO TIME RESULTS-USING F/O CLOCK.

PERFORM ENGINE/ FUEL FLOW REGULATOR HEALTH CHECK FOR -524 ENGINES BY PERFORMING THE FOLLOWING POWERPLANT TESTS.

XXXXX 1. PERFORM N1 SETTING AND GROUND/FLIGHT IDLE TEST - TEST NO. 3.
 I.A.W. AMM 71-00-00 PAGE BLOCK 501.

XXXXX 2. PERFORM I.P. COMPRESSOR AIRFLOW CONTROL TEST - TEST NO. 4.
 I.A.W. AMM 71-00-00 PAGE BLOCK 501.

XXXXX 3. PERFORM V.I.G.V. AIRFLOW CONTROLL UNIT RESPONSE TEST - TEST 4A.
 I.A.W. AMM 71-00-00 PAGE BLOCK 501.

A. Record the five V.I.G.V. scheduling test points used during this test are as follows:

1.18 1.30 1.42 1.53 T/O

#1 ENGINE FFR HEALTH CHECK

A/C NUMBER:

CHECK BEING PERFORMED: Cust

W/C NUMBER: 541F7301 (continued)

MECH: INSP:

(1) OBS N1	_____	_____	_____	_____	_____
(2) TEMP CORR N1	_____	_____	_____	_____	_____
(3) CORR (%) N1	_____	_____	_____	_____	_____
(4) OBS TGT	_____	_____	_____	_____	_____
(5) OBS N3	_____	_____	_____	_____	_____
(6) TEMP COR N3	_____	_____	_____	_____	_____
(7) CORR (%) N3	_____	_____	_____	_____	_____
(8) OBS N2	_____	_____	_____	_____	_____
(9) OBS FF	_____	_____	_____	_____	_____

XXXXX 4. PERFORM PERFORMANCE TEST - TEST NO. 7.
I.A.W. AMM 71-00-00 PAGE BLOCK 501.

XXXXX 5. PERFORM VIBRATION SURVEY - TEST NO.11.
I.A.W. AMM 71-00-00 PAGE BLOCK 501.

A. Make a recording at which peak vibration occurs.

	Pickup A	Pickup B
(1) Norm	_____	_____
(2) Low	_____	_____
(3) Med	_____	_____
(4) High	_____	_____

XXXXX 6. PERFORM ACCELERATION AND DECELERATION TEST - TEST NO. 8.
I.A.W. AMM 71-00-00 PAGE BLOCK 501.

XXXXX 7. VERIFY THAT A STANDARD 30-MICRON OIL PRESSURE-FILTER ELEMENT IS
IS INSTALLED. (SEE FIGURE 1)

NOTE: A 3-MICRON SLAVE PRESSURE FILTER SHOULD NOT BE INSTALLED,
AS IT IS FOR TEST PURPOSES ONLY AFTER A MODULE OR
MINI-MODULE CHANGE TO THE ENGINE. THE SLAVE END COVER IS

#1 ENGINE FFR HEALTH CHECK

PAGE: 3 / 3

A/C NUMBER:

CHECK BEING PERFORMED: Cust

W/C NUMBER: 541F7301 (continued)

MECH: INSP:

| PAINTED RED AND HAS AN ATTACHED TAG STATING "THIS TOOL
| MUST BE REMOVED AFTER USE".

*****END OF WORKCARD*****

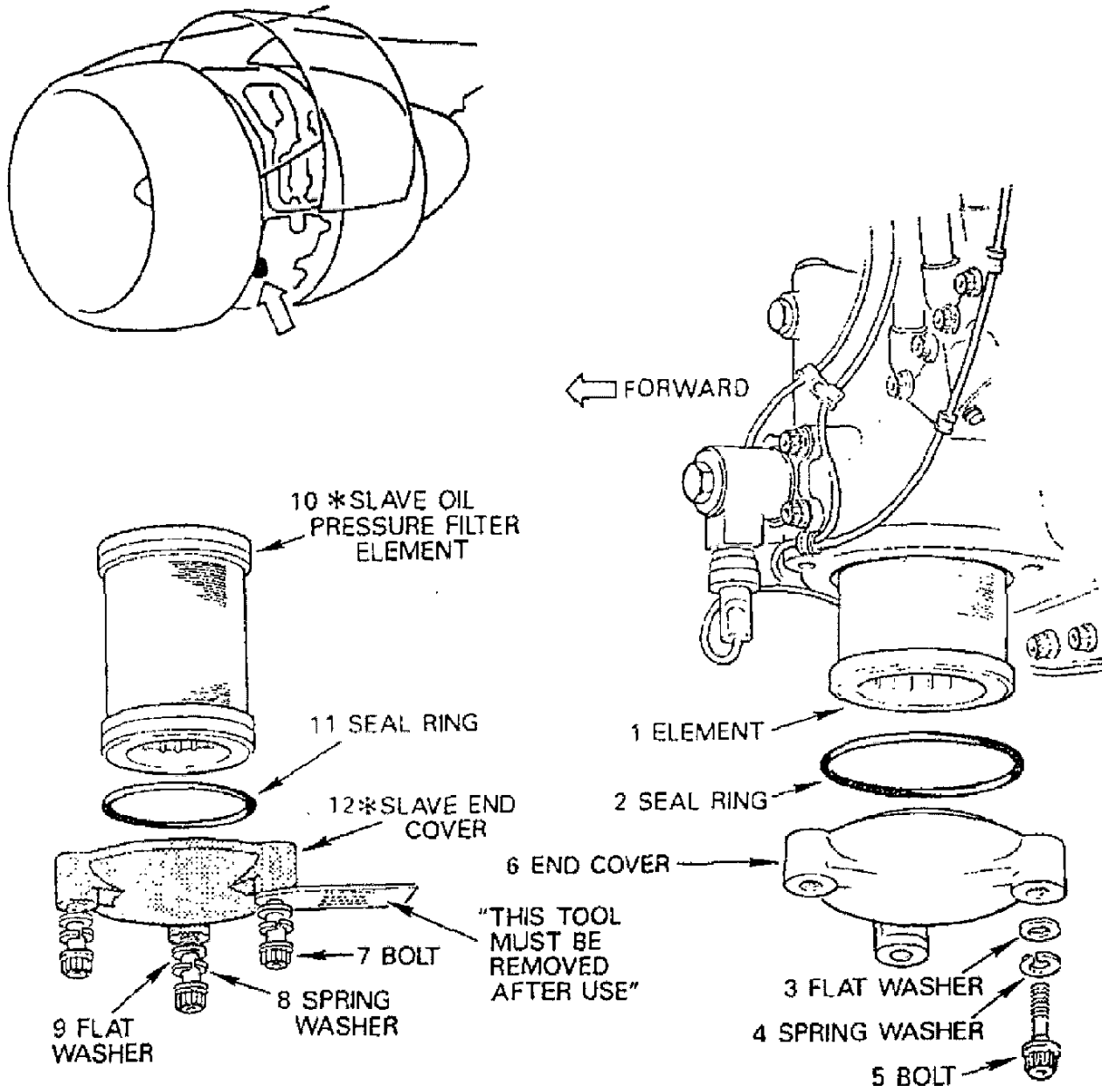

 Parts painted in red

* Parts of test tools

Slave Pressure Filter Element Configuration

Standard Pressure Filter Element Configuration

FIGURE 1

REVISION DATE 03/29/2006