

CHECK BEING PERFORMED: Custom

ZONES: 100 410 420 430
 A/C NUMBER:
 REV. DATE: 03/16/00
 FREQUENCY: H1

W/C NUMBER: 590M2902
 DATE:
 W/O:
 JAC CODE:



REFERENCES

FIGURE 1 MM 29-32-00

590M2902

MECH INSP

-
- 1 CHECK CONDITION OF THE FOLLOWING HYDRAULIC SYSTEM FILTER MODULES AND ENSURE DIFFERENTIAL PRESSURE INDICATORS HAVE NOT DEPLOYED. (SEE FIGURE 1)

NOTE: GENERATE NON ROUTINES TO TROUBLE SHOOT SYSTEM AND REPLACE FILTERS AS REQUIRED IF ANY DIFFERENTIAL PRESSURE INDICATOR IS DEPLOYED.

LH PYLON

_____ XXXXX A HIGH PRESSURE FILTER MODULE
 _____ XXXXX B SINGLE BOWL CASE DRAIN FILTER MODULE

LH AFT BODY

_____ XXXXX C HIGH PRESSURE FILTER MODULE
 _____ XXXXX D SINGLE BOWL CASE DRAIN FILTER MODULE

SERVICE CENTER

E SYSTEM A

_____ XXXXX 1 HIGH PRESSURE FILTER MODULE
 _____ XXXXX 2 RETURN FILTER MODULE
 _____ XXXXX 3 SINGLE BOWL CASE DRAIN FILTER MODULE

F SYSTEM B

_____ XXXXX 1 HIGH PRESSURE FILTER MODULE
 _____ XXXXX 2 RETURN FILTER MODULE
 _____ XXXXX 3 SINGLE BOWL CASE DRAIN FILTER MODULE
 _____ XXXXX 4 DUAL BOWL CASE DRAIN FILTER MODULE

HYDRAULIC FILTER DIFFERENTIAL PRESSURE INDICATOR CHECK

A/C NUMBER:

CHECK BEING PERFORMED: Cust

W/C NUMBER: 590M2902 (continued)

MECH: INSP:

-
- _____ XXXXX A FWD INDICATOR
 - _____ XXXXX B AFT INDICATOR
 - G SYSTEM C
 - _____ XXXXX 1 HIGH PRESSURE FILTER MODULE
 - _____ XXXXX 2 RETURN FILTER MODULE
 - _____ XXXXX 3 SINGLE BOWL CASE DRAIN FILTER MODULE
 - 4 DUAL BOWL CASE DRAIN FILTER MODULE
 - _____ XXXXX A FWD INDICATOR
 - _____ XXXXX B AFT INDICATOR
 - H SYSTEM D
 - _____ XXXXX 1 HIGH PRESSURE FILTER MODULE
 - _____ XXXXX 2 RETURN FILTER MODULE
 - _____ XXXXX 3 SINGLE BOWL CASE DRAIN FILTER MODULE
 - AFT BODY RH
 - _____ XXXXX I HIGH PRESSURE FILTER MODULE
 - _____ XXXXX J SINGLE BOWL CASE DRAIN FILTER MODULE
 - RH PYLON
 - _____ XXXXX K HIGH PRESSURE FILTER MODULE
 - _____ XXXXX L SINGLE BOWL CASE DRAIN FILTER MODULE

*****END OF WORKCARD*****

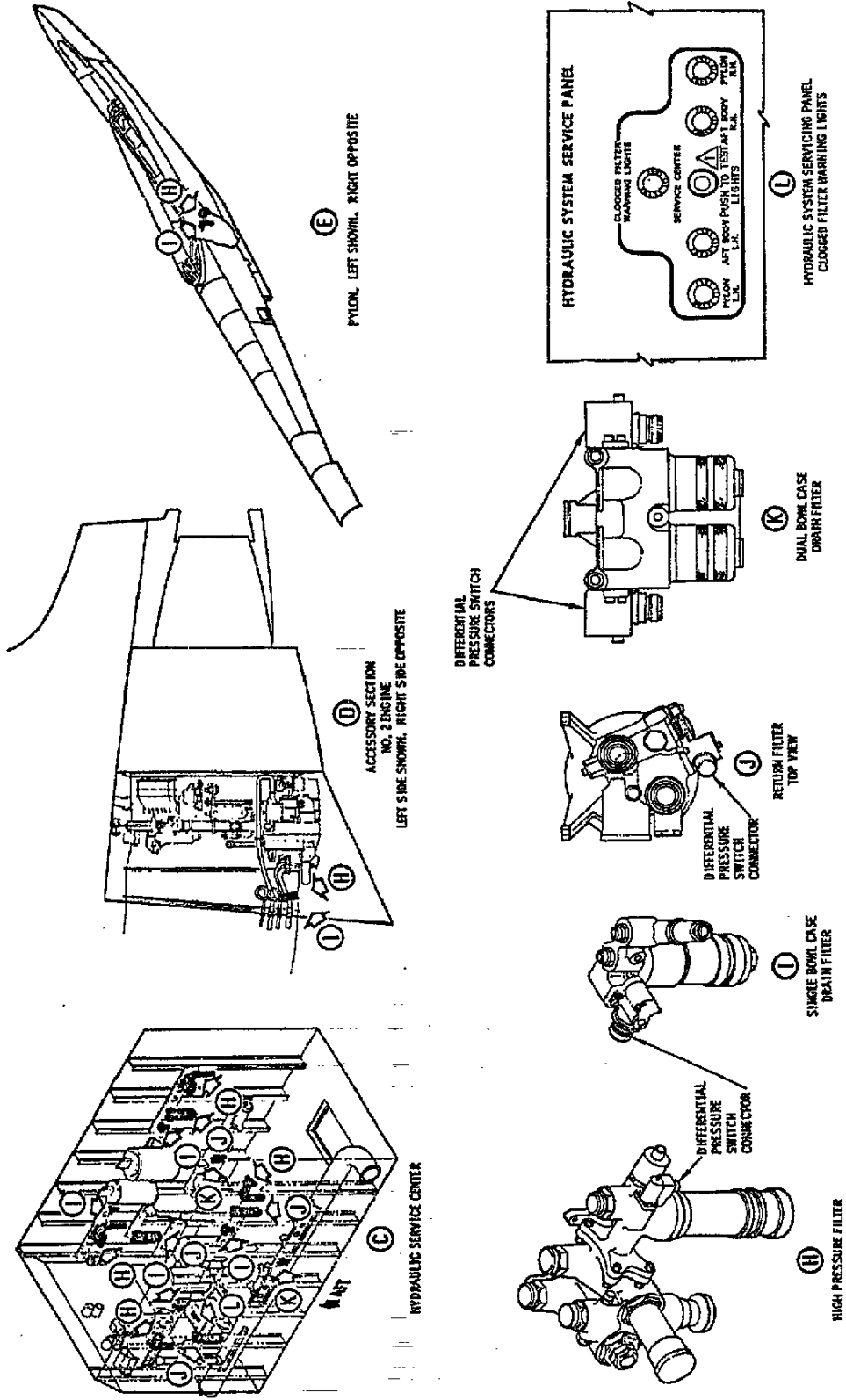

Filter Differential-pressure Caution Indicating System

FIGURE 1